

MADE IN ITALY



INDUSTRIAL range



CUBE SD

Silenced Rotary
Screw Compressors



Fixed Speed
4-7.5 kW

CUBE SD

Silenced rotary screw compressors

Main features and advantages

Reliable direct transmission for energy saving

The whole power of the electric motor is then transferred to the airend with maximum efficiency and reliability of operation.

Rotar CUBE SD series are built for continuous duty in very hard conditions of use. The design of the machine has been focused non only on power consumption, but also on maintenance and operational costs and installation ease.

The Cube SD range represents an outstanding machine in the compressed air market also due to the integrated refrigerating dryer which can be host in the compressors frame, with no change in shape or dimensions.

Compact and silent

The Rotar CUBE SD models are available with power from 4 to 7.5 kW and noise level between 63 and 68 dB(A). The whole machine is extremely silent and compact with balanced dimensions.

Cooling system

An axial fan grants the optimal cooling air flow through an oversized heat exchanger. The fan operation is thermostatic controlled by ETMII controller monitoring the airend operational temperature. All air and oil pipes are made of heat-resistant rubber.

Control of the working pressure with transducer

It guarantees an accurate and stable operation during the time. The transducer allows direct modification of the working pressure from the electronic controller without any mechanical intervention. Actual pressure and temperature are always displayed on the controller.

Simple maintenance

All of the internal mechanical and service parts are easy to access, for fast and simple routine maintenance.



only
63 dB(A)



POWER: 4 - 5.5 - 7.5 kW

MAX. PRESSURE: 10 bar

MADE IN ITALY



Low noise level

CUBE SD compressors are very quiet: the use of very efficient soundproofing materials means that they are suitable for installation in any working environment.



Available versions:

- floor mounted compressor
- compressor + air receiver
- compressor + air receiver + air dryer
(air receiver: 270 or 500 liters)

CUBE SD

Silenced rotary screw compressors

Main components



Transmission

The drive between the air-end and electric motor is carried out by means of gearless direct connection. Optimal power transmission and maximum reliability and efficiency. A dedicated air-end for any machine at any pressure in order to grant maximum performance in the complete range. The small dimensions of the screw-engine connecting system allows to realize a very compact machine.



Integrated air dryer

ROTAR CUBE SD is available in "ES" version with integrated dryer, entirely included in the machine.

Immediately ready to operate without any installation effort.

It provides clean, dry air that improves the system's reliability, avoids costly downtime and production delays, and safeguards the quality of your products.

The dryer is equipped with a control panel and a timed condensate drain.



SPIN-ON filters

Routine service parts that are simple to replace offering long service intervals for lower maintenance costs.

Oil separator tank

Comply with the CE 87/404 regulation and assure an excellent oil-air pre-separation, increasing the efficiency of the oil separating filter.



Intake regulator

IR10 intake regulator designed and manufactured by Fini.



Easily transportable

The machine is particularly easy to lift with a fork truck or hand truck thanks to a steel bar secured between the feet at the base of the air receiver (both at the front and to the side).

Condensate ball valve

Receiver-mounted models with ball valve for convenient discharge of condensate (refer to local regulations).



ETMII advanced controller

Controller with multi-function backlight display, the menu is alphanumeric type. The main screen display indicates:

- Working pressure (offload/load);
- Oil temperature;
- Total working hours;
- On-load working hours;
- Compressor status led (stand-by, offload, load);
- Hours remaining before maintenance.

Four maintenance timers (air filter, oil, oil filter, oil separator).

- Automatic re-start after power failure (subject to safety conditions).
- Cooling fan temperature control.
- Compressor remote start facility.
- Integrated phase sequence relay.



FS 26TFC High performance screw air-end







The Fini air ends are entirely designed, produced and tested at our Italian facilities: the special design of the screw profile ensures high performance, low temperature and reduced energy consumption.



CUBE SD

Silenced rotary screw compressors

Technical data

Code	ℓ	Product			 AIR									
			kW	HP	l/min.	m³/h	c.f.m.	bar	psi	dB(A)	BSP	L x D x H (cm)	kg	Lbs
FLOOR MOUNTED														
V51PD92FNM043	–	CUBE SD 510	4	5,5	460	27,6	16,2	10	145	63	1/2"	65 x 58 x 80	108	238
V51PE92FNM043	–	CUBE SD 710	5,5	7,5	705	42,3	24,9	10	145	68	1/2"	65 x 58 x 80	101	223
V51PO92FNM043	–	CUBE SD 1010	7,5	10	1050	63	37,1	10	145	67	1/2"	65 x 58 x 80	115	254
WITH AIR RECEIVER														
V91PD92FNM001	270	CUBE SD 510-270F	4	5,5	460	27,6	16,2	10	145	63	1/2"	120 x 60 x 150	185	408
V91PE92FNM001	270	CUBE SD 710-270F	5,5	7,5	705	42,3	24,9	10	145	68	1/2"	120 x 60 x 150	185	408
V91PO92FNM001	270	CUBE SD 1010-270F	7,5	10	1050	63	37,1	10	145	67	1/2"	120 x 60 x 150	197	434
V83PO92FNM001	500	CUBE SD 1010-500F	7,5	10	1050	63	37,1	10	145	67	1/2"	200 x 60 x 150	242	534
WITH AIR RECEIVER AND DRYER														
V91PE92FNM101	270	CUBE SD 710-270F ES	5,5	7,5	705	42,3	24,9	10	145	68	1/2"	120 x 60 x 150	206	454
V91PO92FNM101	270	CUBE SD 1010-270F ES	7,5	10	1050	63	37,1	10	145	67	1/2"	120 x 60 x 150	218	481
V83PO92FNM101	500	CUBE SD 1010-500F ES	7,5	10	1050	63	37,1	10	145	67	1/2"	200 x 60 x 150	263	580

Optional

#448417000	Air dryer
------------	-----------

Long Life Kit

The "FSN" brand states the originality of the components, which are specifically manufactured and tested to be used on our compressors. The use of original, certified spare parts guarantees the efficiency and reliability of the compressor, extending its lifespan and lowers management costs. The experience we have acquired in over 65 years of business in the compressed air industry has led to the creation of the "Long Life Kit", specifically conceived to extend compressor lifespan upon the first service tasks. Easy and intelligent solutions to keep the compressor as though it were "brand new".



SCHEDULED MAINTENANCE		
every 2,000 hrs (or every year)	every 4,000 hrs (or every year)	every 8,000 hrs
MINERAL OIL	SYNTHETIC OIL	SYNTHETIC OR MINERAL OIL
KIT A		KIT B
1 Air filter cartridge 1 Oil filter cartridge 1 Separator cartridge 1 Oil check valve		1 Kit A 1 Solenoid valve
CUBE SD 510	#260KTB24E	#260KTE1HE
CUBE SD 710		
CUBE SD 1010	#260KTB84E	#260KTE1KE

SINGLE COMPONENTS			
every 4,000 hrs	every 8,000 hrs	every 20,000 hrs	
Intake regulator kit	Minimum pressure valve kit	Air-end kit	Air-end
CUBE SD 510	#260249050	#347111000	#230300200
CUBE SD 710			#5303000210
CUBE SD 1010			#5303000705
			#5303000210

Oil

Our FSN lubricants - whether synthetic or mineral - have been specially developed for our screw compressors top quality operativity in cooperation with a world leading manufacturer of Industrial lubricants. Available in various packaging formats and capacities and in multiple or 'bulk' packages.



Rotar ECOFLUID 46 cSt oil - Mineral base

#600000020	1 x 3.8 L (3.3 kg) tank
#600000021	1 x 20 L (17.36 kg) tank
#600000022	1 x 200 L (174 kg) drum

Formulated with high quality selected mineral base oils enhanced with advanced anti-oxidants, anti-wear (zinc free), rust preventers and antifoams, offers an optimal control of oxidation and residue deposits as well as an excellent level of thermal stability and oxidation to ensure the longevity of equipment and long life performances.



RotEnergy Plus 46 cSt oil - Synthetic base

#600000018A	1 x 3.8 L (3.25 kg) tank
#600000009A	4 tanks x 3.8 L (3.25 kg) each
#600000007A	1 x 19 L (16 kg) tank
#600000012A	1 x 208 L (181 kg) drum

Ensures low operating temperatures, efficient water separation, reduces friction and energy consumption, extends maintenance intervals, ensures excellent lubrication of the bearings, guaranteeing maximum all round protection.



RotEnergyFood 46 cSt oil - Synthetic base

#600000014A	4 tanks x 3.9 L (3.25 kg) each
#600000016A	1 x 19 L (18.5 kg) tank
#600000017A	1 x 208 L (175 kg) drum

High-quality lubricant for rotary screw compressors, suitable for use in the food industry, where specific quality standards are required.

We recommend changing the oil according to the intervals reported in the use and maintenance manual of the compressor or once a year. We suggest using our RotarECOFLUID or RotEnergy oil (that are not included in the Long Life Kit).

A wide range of solutions for industrial applications



MICRO - PLUS

Oil-injected rotary screw compressors, with belt transmission, at fixed or variable speed and power values from 2.2 to 75 kW.



K-MAX

Oil-injected rotary screw compressors, with direct transmission with or without gears, at fixed or variable speed and power values from 5.5 to 90 kW.



TERA

Oil-injected rotary screw compressors, with direct transmission without gears, at fixed or variable speed and power values from 110 to 250 kW.



OS Scroll

Single and multi-scroll fixed speed oil-free compressors with power values from 2.2 to 30 kW.



AIR TREATMENT

Air driers, filters, accessories and a wide range of products for compressed air treatment.



FNA S.p.A.

Registered office, Headquarter and Sales Dept.:

Via Einaudi, 6 - 10070 Robassomero (TO) - Italy - Tel.: +39 011 9233000 - Fax: +39 011 9241138

Production plant:

Via Toscana, 21 - 40069 Zola Predosa (BO) - Italy

www.finicompressors.com - info@fnacompressors.com



CE IE3

MADE IN ITALY



INDUSTRIAL range



MICRO - PLUS

Belt-driven oil-injected rotary screw compressors



Fixed and Variable Speed
2.2-75 kW

Company Profile

FINI boasts more than 70 years of experience and is one of the most important global organisations in the professional and industrial compressed air sector. Synonymous with quality and professionalism, the Fini brand not only provides one of the most comprehensive ranges in the field of rotary air compressors, but above all Fini is now established as a global reference point in terms of quality and technology recognised throughout the industrial compressed air sector.



All Fini industrial compressors are **MADE IN ITALY** and are designed for heavy duty use and distinguished by offering unique and advanced technologies that provides energy saving solutions that work!

► Our compressors offer the ideal solution to the needs of larger-scale industry as well as smaller and mid-sized companies, where compressed air is a most important source of energy.

Fini Screw Compressors are designed for continuous duty in the most arduous operating conditions, with a special attention to reducing energy consumption, lowering operating and maintenance costs along with offering simple installation and ease of use.

► The entire production process, from project design and research through to packaging of the final product is carried out at our facilities in Italy.

Our highly skilled work force are dedicated to supporting the manufacturing and assembling activities. The continuous control and monitoring of each manufacturing process grants the utmost precision at every step, in order to achieve the highest quality, supreme product reliability and flexibility of use.

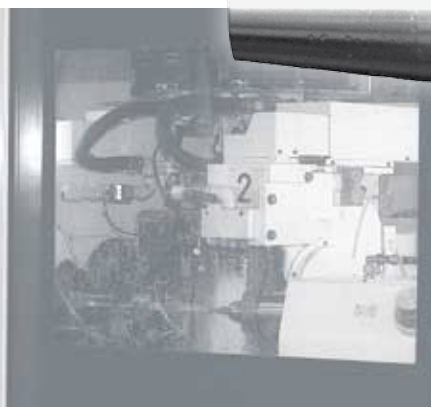
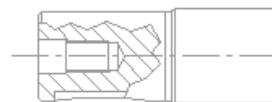

Innovation, Quality and Know-how

Our engineering philosophy is based on the selection and highly controlled assembly of the most reliable and efficient technical solutions. The constant pursuit of excellence in quality along with an innovative spirit and particular attention to the customers demands, are the values that have always characterised FINI and its products.



► The continuous investment in technical design and product innovation has allowed FINI to take a further step forward in the sector, with the launch of the latest range of industrial air compressors- **MICRO and PLUS Series: oil-injected belt-driven rotary screw compressors**, in an extensive range from 2.2 kW to 75 kW.

► During production all of the assembly and testing of products is performed on automated assembly lines that utilise the latest robotic systems. The use of the most advanced and modern machine tools in manufacturing coupled with the employment of advanced controls and processes have been a major focus for the Company representing a very significant investment in order to create products that exceed the quality standards demanded by the market.

Since 1996, the Company has certified its quality systems in compliance with UNI EN ISO 9001.

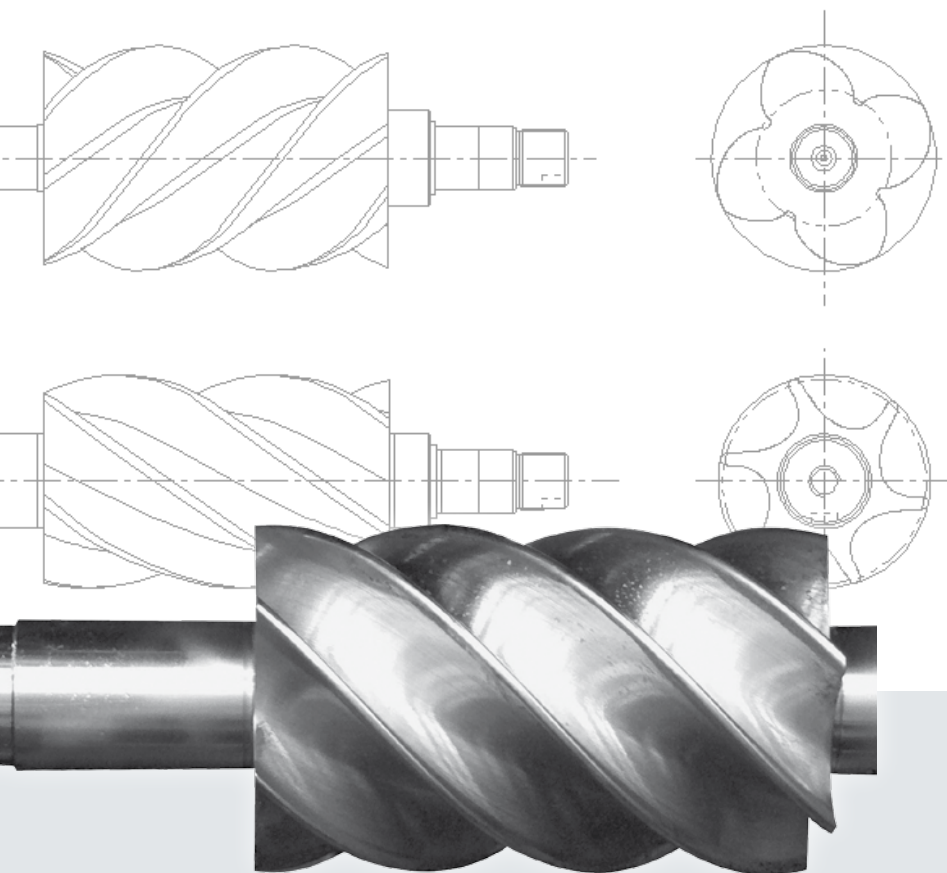

Our TARGET: Maximum efficiency, lower energy consumption and total convenience.

The new belt-driven oil injected Micro and Plus screw compressors have been designed to minimise energy costs, without sacrificing performance. The modularity and flexibility of these products provide multiple solutions suitable for different user's requirements: with or without air receiver, with or without refrigerated dryer, in fixed speed or variable speed formats.



Why you should choose a Fini SCREW compressor?

- ▶ To control and reduce operating costs.
- ▶ To provide the most modern, compact, robust, reliable and quiet rotary screw compressor.
- ▶ To provide a continuous source compressed air.
- ▶ To increase operational efficiency in all areas where compressed air is used.
- ▶ To save energy and reduce CO₂ emissions.

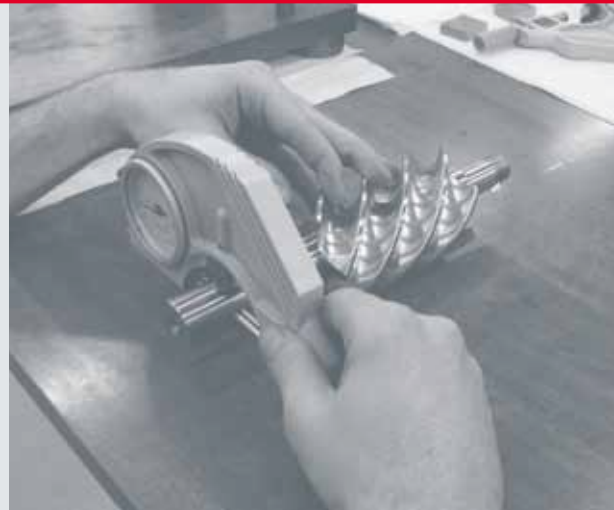

High energy saving

The choice of high quality components, combined with our high performance air-ends and **Premium Efficiency IE3 motors**, ensure reduced power consumption, substantial energy savings and exceptional performance. Furthermore, the IE3 motors reduce CO₂ emissions: an important contribution to protecting the environment.

Plug&Play

Micro and Plus compressors are thoroughly tested at our factories to ensure they are ready for immediate use following delivery, thereby saving time and cutting installation costs.



Low noise level

Micro and Plus compressors are very quiet: the use of very efficient soundproofing materials means that they are suitable for installation in any working environment.

High reliability

The use of premium components from primary global manufacturers along with our advanced assembly with strict quality control and testing, results in a final product that offers a long service life with maximum reliability and fewer maintenance interventions.

High efficiency

Higher air output performance is a key focus for the renowned FINI project engineering and design team. The new Micro and Plus series follows this tradition by offering premium performance levels across the entire range.

Very compact design

The very compact design enables Micro and Plus compressors to be installed close to the application reducing installation costs and improving efficiency.

Our air-ends, inverters and controllers are covered by **2 YEARS WARRANTY**

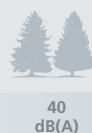

Designed to offer a long service life



1 Innovative cooling system

The cooling system is among the most innovative in the field. A thermostatic controlled centrifugal fan keeps the temperature of the entire compressor to specific tolerance and at a constant level, avoiding temperature peaks that can be harmful for the correct operation of the compressor. The action of the fan, combined with the efficiency of the oversized oil cooler, guarantees the ideal operation of the compressor in differing and even extreme climatic conditions.

The "silent" fans along with the specially developed labyrinth ventilation and the use of high quality soundproofing materials ensure one of the lowest acoustic levels of any air compressor.

2 Efficient transmission

The POLY-V belt drive ensures significantly lower power losses and three times longer service life compared to standard range "V" type belts fitted to other compressors on the market. simple belt tensioning is carried out through a sliding belt tensioner.

3 High performance flexible tubing

All air-oil circuit flexi-tubes are of premium quality and made of multi layer rubber covered with a metal mesh which are resistant to very high temperatures and capable of operation at high pressure.

4 Intake valve

The intake valve is entirely designed and manufactured at our facilities. This most important device, adjusts the compressor's operation to guarantee minimum pressure during idle running and maximum savings upon start-up.

5 Pressure transducer

The use of a digital transducer guarantees an accurate and stable function during operation. It allows direct modification of the working pressure from the electronic controller without any mechanical intervention.



Noise and temperature under control

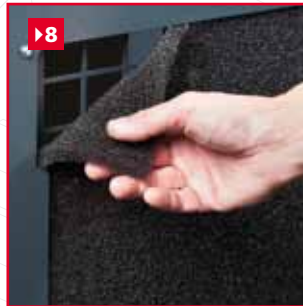

►10 High performance ROTARY SCREW AIR-ENDS

The Fini FS air ends are entirely designed, produced and tested at our Italian facilities: the special design of the screw profile ensures high performance, low temperature and reduced energy consumption.

►6 SPIN-ON filters

Routine service parts that are easy to remove and replace offering long service intervals for lower maintenance costs.

Air filters

Protecting the compressor the oversized filter mass with double filtering media allows operation even in arduous environments.

►7 Minimum pressure valve

Manufactured and designed in house using advanced anti corrosive materials and fully machined at our facilities, to grant maximum reliability in any operating conditions.

►8 Cleaner components in any conditions

A cabinet prefiltering panel (available from 18.5 kW) inhibits dust and dirt from entering the inside of the compressor cabinet increasing the life of air filters and the drive belt by 15%, whilst keeping coolers cleaner thereby reducing operating temperature.

►9 Simple maintenance

All of the internal mechanical and service parts are easy to access, for fast and simple routine maintenance.

MICRO 2.2-5.5 kW: simple, silent and economical.

- ▶ Extremely quiet operation.
- ▶ Very compact design.
- ▶ Anti-rotation system.
- ▶ Low maintenance costs.
- ▶ Ease of installation and use.
- ▶ Plug and play.



The MICRO range is available in 2 versions:

- **MICRO "SE" 2.2-4 kW:** electromechanical ON/OFF switch, with motor protection.
The pressure gauge and hour counter are included in the control panel.
Easy to use, no idle running means considerable energy saving.

- **MICRO 4-5.5 kW:** star-delta starter, including the ETMII electronic controller, which controls the complete operation of the machine.

Micro SE 2.2-3.0-4.0

2.2-4 kW

Available versions:

- floor mounted compressor
- compressor + air receiver
- compressor + air receiver + air dryer
(air receiver: 200 liters)

Air-end:
FS14



Controller:
-

-

Fixed speed

Micro 4.0-5.5

4-5.5 kW

Available versions:

- floor mounted compressor
- compressor + air receiver
- compressor + air receiver + air dryer
(air receiver: 200, 270 or 500 liters)

Air-end:
FS14



Controller:
ETMII

ETMII



Fixed speed

PLUS 7.5-15 kW: the modular choice.



- ▶ Extremely quiet operation.
- ▶ Very compact design.
- ▶ High efficiency.
- ▶ Low R.P.M.
- ▶ Ease of installation and use.
- ▶ Plug and play.

Dryer module ▶

The models with air receiver are also available with dryer ("ES" versions): supplied ready to operate with a minimum of installation.



Condensate ball valve (1)

Receiver-mounted models with ball valve for convenient discharge of condensate (refer to local regulations).

Easy to transport (2)

The machine is particularly easy to lift with a fork truck or hand truck thanks to a steel bar secured between the feet at the base of the air receiver (both at the front and to the side).

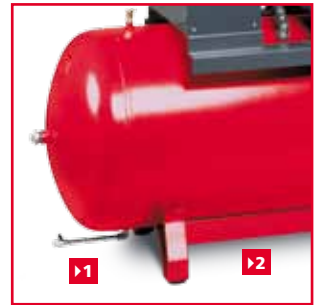

Plus 8-11-15

7.5-15 kW

Available versions:

- floor mounted compressor
- compressor + air receiver
- compressor + air receiver + air dryer (air receiver: 270 or 500 liters)

Air-end:
FS26 TF



Controller:
ETMII



Fixed speed

Plus 16

15 kW

Available versions:

- floor mounted compressor
- compressor + air receiver
- compressor + air receiver + air dryer (air receiver: 500 liters)

Air-end:
FS50 TF



Controller:
ETMII



Fixed speed

PLUS 18.5-37 kW: new design with higher performance.

The new PLUS compressors from 18.5 to 75 kW are entirely designed and manufactured so that they function as an integrated system with the maximum efficiency.

All of the most important components within the compressor are manufactured in house using state of the art methods including the use of very modern machine tool and process control technology: this allows full control of the production cycle and maximum control in respect to the total quality of the entire compressor.

The cooling air flow, channeled by the thermostatic controlled centrifugal fan, provides maximum circulation to the oversized combined oil/air heat exchanger: this permits the compressor to run at optimised temperature even in severe ambient conditions.



◀ **Dryer module**
Plus 18.5, 22, 31 and 38 models with dryer module (ES) provide clean, dry air that improves the system's reliability, avoids costly downtime and production delays, and safeguards the quality of the final product.



Plus 18.5-22

18.5-22 kW

Available versions:

- base compressor
- compressor + air dryer

Air-end:
FS50TF



Controller:
ETIV



Fixed or Variable Speed (Plus 22 VS)

Plus 31-38

30-37 kW

Available versions:

- base compressor
- compressor + air dryer

Air-end:
FS100
FS130



Controller:
ETIV



Fixed or Variable Speed (Plus 38 VS)

PLUS 45-75 kW: a quality choice.

- ▶ Extremely quiet operation.
- ▶ High performance screw air-end.
- ▶ Ease of access for routine maintenance.
- ▶ Low maintenance costs.
- ▶ Ease of installation and use.
- ▶ Prefiltering panel.



Plus 45-55

45-55 kW

Available versions:
- base compressor

Air-end:
FS130



Controller:
ETIV



Fixed speed



Plus 56-75

55-75 kW

Available versions:
- base compressor

Air-end:
FS250



Controller:
ETIV



Fixed or Variable Speed (Plus 56 and Plus 75 VS)

Advanced electronic controllers

ETMII

Installed on models from 4 to 15 kW.



- ▶ Four maintenance timers (air filter, oil, oil filter, oil separator).
- ▶ Automatic re-start after power failure (subject to safety conditions).
- ▶ Cooling fan temperature control.
- ▶ Compressor remote start facility.
- ▶ Integrated phase sequence relay.

Controller with multi-function backlight display, the menu is alphanumeric type. The main screen display indicates:

- Working pressure (offload/load);
- Oil temperature;
- Total working hours;
- On-load working hours;
- Compressor status led (stand-by, offload, load);
- Hours remaining before maintenance.

ETIV

Installed on models from 18.5 to 75 kW.



Controller with multi-function backlight LCD graphic display, the menu is drop down type. The main screen display indicates:

- ▶ operating pressures;
- ▶ oil temperature;
- ▶ compressor status (stand-by, un-loaded, loaded);
- ▶ fan status (off/on);
- ▶ date and time;
- ▶ remaining hours for maintenance;
- ▶ flow rate supplied percentage
- ▶ Duty cycle compressor (tot. hours a carico)

▶ Weekly programming

With the ETIV controller, it is possible to set up to 9 independent operating programs.

For each program it is possible to set the switching on and off times, the days of the week in which it must work and the relative pressure range.

In case of a system with several compressors, both at fixed and variable speed, it is possible to set various programs to create a "virtual network" (without the need to physically connect them together).

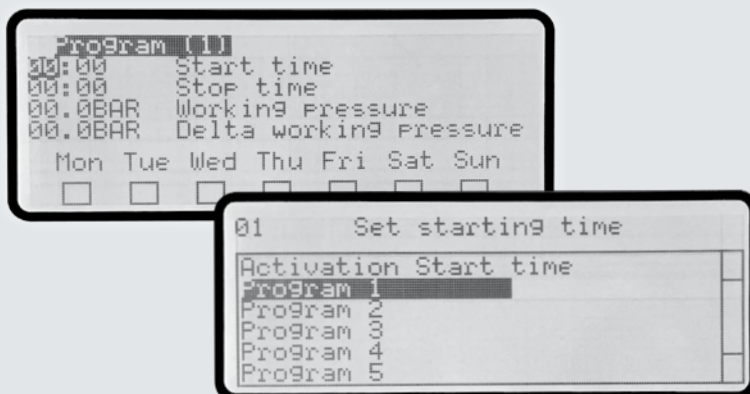

Variable speed drive

Nowadays, the reduction of the energy consumption has become a global challenge in terms of environmental impact. Reducing power consumption and protecting our valuable energy resources represents one of the greatest global environmental challenges of our times.

The Plus series version with 22, 37, 55 and 75 kW electric motor are available in a variable speed drive version, providing high performance combined with the most effective energy saving solution.

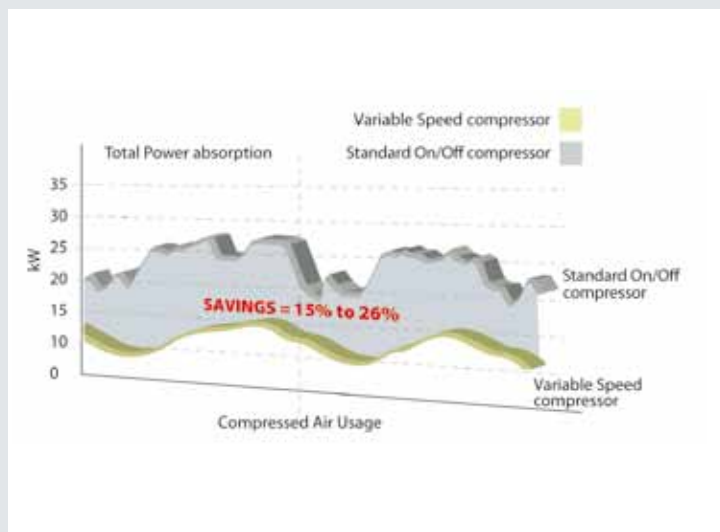

The graph below shows the significant energy saving using variable speed compressors in a typical installation.

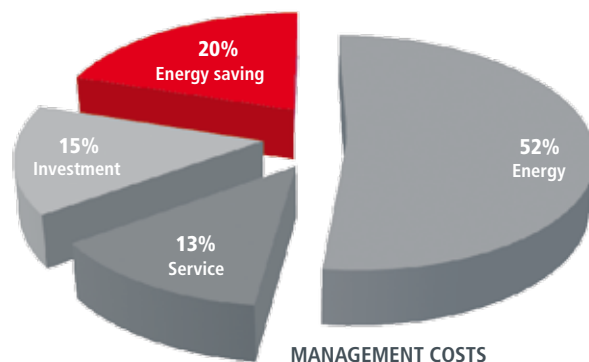

The application of a frequency inverter, able to dynamically adjust the voltage/frequency/current values of the motor, allows the elimination of unnecessary power losses by constantly adjusting the generation of compressed air to match the real air demand, offering many proven advantages for the user in terms of reducing energy consumption:

- ▶ Continuous regulation of the motor speed and compressed air generation to precisely match the air demand.
- ▶ The air output is constantly adjusted between 40% and 100% of the compressor full capacity.
- ▶ Constant and accurate air pressure control selectable at any value between 6 and 10 bar (13 bar on demand).
- ▶ Energy consumption is proportional to the delivered compressed air so you only pay for the compressed air that is used!

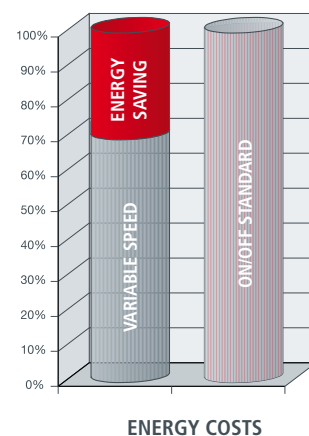

SMS Device Service Management System

SMS is the innovative device for remote control and predictive maintenance of screw compressors fitted with an ETIV controller. If the device is configured on internet networks via Wi-Fi or Ethernet, e-mails can be automatically sent in case of faults and/or automatic periodic e-mails (every hour, every day, every week) so as to monitor correct compressor operation and the remaining hours for the main scheduled maintenance.

Preventive and targeted maintenance:

- ▶ automatic sending of e-mails in case of alarms,
- ▶ possibility of sending e-mails which notify the compressor status and settings at pre-set intervals (hourly, daily or weekly).

Remote control of the compressor:

- ▶ no additional software is required,
- ▶ on/off control,
- ▶ access to the various menu levels (user, service),
- ▶ compressor online status check.



9062744

ANTENNA+SMS DEVICE KIT



EATool - EASoftware Detection and analysis of energy consumption

The energy efficiency of a production plant using compressed air allows for countless advantages for the company's entire production process, in terms of consumption and costs.

Based on decades of experience in the industrial sector, Fini provides a professional auditing service to companies, through skilled technicians and advanced measurement and analysis equipment (EATool and EASoftware). Such equipment allows us to offer one or more rotary screw compressors, in alternative to the existing ones, to achieve considerable annual economic and energy savings.



EATool

- ▶ Designed to measure pneumatic systems where up to 4 compressors work.
- ▶ Measurements are downloaded to a USB drive (included).
- ▶ Supplied: up to 4 x 400 A ampere clamps (optional up to 1000A) and a pressure probe.
- ▶ Possible equipment sale or rental.

EASoftware

- ▶ Acquires the actual consumption of a compressed air system.
- ▶ Processes a complete Energy Audit of the system.
- ▶ Suggests one or more compressors as an alternative to the existing ones, to achieve the highest energy savings.

Optimised control in the compressor room

Many compressed air stations include several compressors: EasyX4 is a weekly programmable sequencer, capable of configuring up to 4 compressors, based on the amount of air actually required.

EasyX4 is the easiest solution for compressor sequencing and supervision over complex systems of compressors, up to 4 units: fixed speed.

The programming is intuitive. It is sufficient to set the 4 pressure ranges (if 4 is the number of connected units) and later define at what time the entire compressor station shall start and stop, assigning at which pressure each compressor must work.



Three programming levels:

- ▶ **MANUAL:** compressors are fixed to a given operational pressure range;
- ▶ **AUTOMATIC:** with pressure range swapping after a programmable time interval;
- ▶ **GROUP PROGRAMMING:** where compressors can be switched within groups.

#405531604 CONTROL UNIT EASY X4

HRS Heat Recovery System

HRS is a system for the recovery of the heat generated by the screw compressors, for the production of hot water.

Most of the energy used to produce compressed air is actually converted into heat: up to 90% of this energy is reusable! About 75% of the energy used is found in the lubrication and cooling circuit and can be used as a heat source, the remaining 15% is contained in the compressed air which enters the network. It is therefore quite simple to recover the thermal energy (for alternative use) in the compression process... valuable energy that is normally wasted!



▶ Plate oil-water heat exchanger

▶ Water pump

The HRS system can be used on all oil-injected screw compressors.

HEAT OF COMPRESSION

- 4% Heat remaining in the air
- 2% Losses by radiation
- 13% Heat removed from the air cooler
- 72% Heat removed from the oil cooler
- 9% Heat radiated by the electric motor

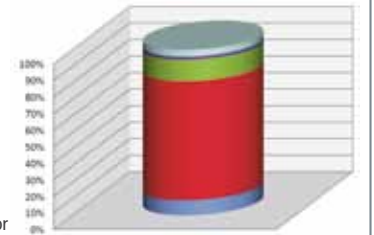

Recover energy - Save money!

How great the recovery of energy actually is, depends of course on the size of the compressors and the type of replaced energy (electricity, gas, heating oil), but the investment becomes very important for the compressors starting from 11 kW installed power. Given the current energy costs, the return on investment of a typical heat recovery system can be as short as 6 months with less than 2 years being the standard (with reference to a plate heat exchanger for heating systems).

Heat recovery is a real opportunity to increase the effectiveness of a compressed air system, the impact on energy costs allows greater savings, up to 3 times compared to even the most efficient compressor.



Long Life Kit for screw compressors scheduled maintenance

- ▶ **FSN original spare parts** have been rigorously selected, checked and tested by specialised technicians to ensure the utmost efficiency and endurance of the compressor. The parts are stocked in our "LOGIMAT" centralised and automated warehouse in Zola Predosa (BO) - Italy, where 12,000 part codes on 10,000 sqm are managed every day.
- ▶ Specialised staff are continuously in contact with our distribution centres worldwide, to deliver spare parts to our customers in the shortest possible time.
- ▶ The use of **FSN Long Life Kit**, specifically studied for screw compressors, extends maintenance intervals, cutting down service costs and ensuring consistent product performance.
Ask for the catalog with reference codes, suitable for all Micro and Plus compressors.



RotarEcofluid mineral based lubricants

- ▶ Formulated with high quality selected mineral base oils enhanced with advanced anti-oxidants, anti-wear (zinc free), rust preventers and antifoams, the FSN RotarECOFLUID oil offers an optimal control of oxidation and residue deposits as well as an excellent level of thermal stability and oxidation to ensure the longevity of equipment and long life performances.

#600000020	Oil RotarECOFLUID 46 cSt - 1 x 3,8 L (3,3 kg) can
#600000021	Oil RotarECOFLUID 46 cSt - 1 x 20 L (17,36 kg) can
#600000022	Oil RotarECOFLUID 46 cSt - 1 x 200 L (174 kg) drum



RotEnergy synthetic based lubricants

- ▶ Our synthetic based lubricants - FSN RotEnergy - have been specifically designed for use on our screw compressors, supplied by world leading manufacturers. They are available in cans, drums or multi packs: RotEnergyPlus: ensures quick water separation and lower friction and energy consumption, it extends maintenance intervals and ensures excellent lubrication of the bearings while offering excellent protection. RotEnergyFood: a high quality lubricant for rotary compressors, suitable for use in the food industry, where specific quality standards are required.

#600000018A	Oil RotEnergyPlus 46 cSt - 1 x 3,8 L (3,25 kg) can
#600000009A	Oil RotEnergyPlus 46 cSt - 4 x 3,8 L (3,25 kg) each cans
#600000007A	Oil RotEnergyPlus 46 cSt - 1 x 19 L (16 kg) can
#600000012A	Oil RotEnergyPlus 46 cSt - 1 x 208 L (181 kg) drum

#600000014A	Oil RotEnergyFood 46 cSt - 4 x 3,9 L (3,25 kg) each cans
#600000016A	Oil RotEnergyFood 46 cSt - 1 x 19 L (18,5 kg) can
#600000017A	Oil RotEnergyFood 46 cSt - 1 x 208 L (175 kg) drum

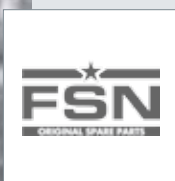

- ▶ On the **FINI** website, it is possible to check out the exploded views and spare parts lists for any compressor model whenever needed.

www.finicompressors.com

- ▶ Our **Hot-Line** service can prepare and ship urgent spare parts orders within a day (if received before 12.00 p.m.).



Code	ℓ	Product	Compressor		AIR			MAX		dB(A)	G	Weight		L x W x H (cm)
			kW	HP	l/min.	m ³ /h	c.f.m.	bar	psi			kg	Lbs	
FLOOR MOUNTED														
V51JT60FNM560	-	MICRO SE 2.2-10 M	2.2	3	240	14.4	8.5	10	145	58	1/2"	98	216	60 x 48 x 76
V51JU72FNM760	-	MICRO SE 2.2-08	2.2	3	325	19.5	11.5	8	116	58	1/2"	93	205	60 x 48 x 76
V51JT72FNM760	-	MICRO SE 2.2-10	2.2	3	290	17.4	10.2	10	145	58	1/2"	93	205	60 x 48 x 76
V51JS72FNM760	-	MICRO SE 3.0-08	3	4	430	25.8	15.2	8	116	59	1/2"	99	218	60 x 48 x 76
V51JQ72FNM760	-	MICRO SE 3.0-10	3	4	385	23.1	13.6	10	145	59	1/2"	99	218	60 x 48 x 76
V51JR72FNM760	-	MICRO SE 4.0-08	4	5.5	580	34.8	20.5	8	116	60	1/2"	108	238	60 x 48 x 76
V51JP72FNM760	-	MICRO SE 4.0-10	4	5.5	485	29.1	17.1	10	145	60	1/2"	108	238	60 x 48 x 76
V51JR92FNM760	-	MICRO 4.0-08	4	5.5	580	34.8	20.5	8	116	60	1/2"	103	227	60 x 48 x 76
V51JP92FNM760	-	MICRO 4.0-10	4	5.5	485	29.1	17.1	10	145	60	1/2"	103	227	60 x 48 x 76
V51JV92FNM760	-	MICRO 4.0-13	4	5.5	330	19.8	11.6	13	188	60	1/2"	103	227	60 x 48 x 76
V51JW92FNM760	-	MICRO 5.5-08	5.5	7.5	720	43.2	25.4	8	116	64	1/2"	127	279	60 x 52 x 78
V51JO92FNM760	-	MICRO 5.5-10	5.5	7.5	650	39	22.9	10	145	64	1/2"	126	277	60 x 52 x 78
V51JM92FNM760	-	MICRO 5.5-13	5.5	7.5	485	29.1	17.1	13	188	64	1/2"	126	277	60 x 52 x 78
WITH AIR RECEIVER														
V77JT60FNM501	200	MICRO SE 2.2-10 M - 200	2.2	3	240	14.4	8.5	10	145	58	1/2"	149	328	144 x 51 x 128
V77JU72FNM701	200	MICRO SE 2.2-08 - 200	2.2	3	325	19.5	11.5	8	116	58	1/2"	144	317	144 x 51 x 128
V77JT72FNM701	200	MICRO SE 2.2-10 - 200	2.2	3	290	17.4	10.2	10	145	58	1/2"	144	317	144 x 51 x 128
V77JS72FNM701	200	MICRO SE 3.0-08 - 200	3	4	430	25.8	15.2	8	116	59	1/2"	149	328	144 x 51 x 128
V77JQ72FNM701	200	MICRO SE 3.0-10 - 200	3	4	385	23.1	13.6	10	145	59	1/2"	149	328	144 x 51 x 128
V77JR72FNM701	200	MICRO SE 4.0-08 - 200	4	5.5	580	34.8	20.5	8	116	60	1/2"	153	337	144 x 51 x 128
V77JP72FNM701	200	MICRO SE 4.0-10 - 200	4	5.5	485	29.1	17.1	10	145	60	1/2"	153	337	144 x 51 x 128
V77JR92FNM701	200	MICRO 4.0-08 - 200	4	5.5	580	34.8	20.5	8	116	60	1/2"	149	328	144 x 51 x 128
V77JP92FNM701	200	MICRO 4.0-10 - 200	4	5.5	485	29.1	17.1	10	145	60	1/2"	149	328	144 x 51 x 128
V91JW92FNM701	270	MICRO 5.5-08 - 270	5.5	7.5	720	43.2	25.4	8	116	64	1/2"	202	444	156 x 57 x 139
V91JO92FNM701	270	MICRO 5.5-10 - 270	5.5	7.5	650	39	22.9	10	145	64	1/2"	202	444	156 x 57 x 139
V83JW92FNM701	500	MICRO 5.5-08 - 500	5.5	7.5	720	43.2	25.4	8	116	64	1/2"	247	543	200 x 60 x 148
V83JO92FNM701	500	MICRO 5.5-10 - 500	5.5	7.5	650	39	22.9	10	145	64	1/2"	247	543	200 x 60 x 148
WITH AIR RECEIVER AND DRYER														
V77JU72FNM801	200	MICRO SE 2.2-08 - 200 ES	2.2	3	325	19.5	11.5	8	116	58	1/2"	162	356	144 x 51 x 128
V77JT72FNM801	200	MICRO SE 2.2-10 - 200 ES	2.2	3	290	17.4	10.2	10	145	58	1/2"	162	356	144 x 51 x 128
V77JS72FNM801	200	MICRO SE 3.0-08 - 200 ES	3	4	430	25.8	15.2	8	116	59	1/2"	179	394	144 x 51 x 128
V77JQ72FNM801	200	MICRO SE 3.0-10 - 200 ES	3	4	385	23.1	13.6	10	145	59	1/2"	179	394	144 x 51 x 128
V77JR72FNM801	200	MICRO SE 4.0-08 - 200 ES	4	5.5	580	34.8	20.5	8	116	60	1/2"	171	376	144 x 51 x 128
V77JP72FNM801	200	MICRO SE 4.0-10 - 200 ES	4	5.5	485	29.1	17.1	10	145	60	1/2"	171	376	144 x 51 x 128
V77JR92FNM801	200	MICRO 4.0-08 - 200 ES	4	5.5	580	34.8	20.5	8	116	60	1/2"	167	367	144 x 51 x 128
V77JP92FNM801	200	MICRO 4.0-10 - 200 ES	4	5.5	485	29.1	17.1	10	145	60	1/2"	167	367	144 x 51 x 128
V91JW92FNM801	270	MICRO 5.5-08 - 270 ES	5.5	7.5	720	43.2	25.4	8	116	64	1/2"	229	504	156 x 57 x 139
V91JO92FNM801	270	MICRO 5.5-10 - 270 ES	5.5	7.5	650	39	22.9	10	145	64	1/2"	229	504	156 x 57 x 139
V83JW92FNM801	500	MICRO 5.5-08 - 500 ES	5.5	7.5	720	43.2	25.4	8	116	64	1/2"	277	609	200 x 60 x 148
V83JO92FNM801	500	MICRO 5.5-10 - 500 ES	5.5	7.5	650	39	22.9	10	145	64	1/2"	277	609	200 x 60 x 148







Free air delivery as per ISO 1217 Annex C, at 7.5 - 9.5 - 12.5 bar at the compressor outlet. ± 3 dB (A) as PNEUROP/CAGI PN-NTC 2.3.



Code	ℓ	Product	Compressor		AIR			MAX		dB(A)	BSP	Weight		L x W x H (cm)
			kW	HP	l/min.	m ³ /h	c.f.m.	bar	psi			kg	Lbs	
FLOOR MOUNTED														
V60NG92FNM760	-	PLUS 8-08	7.5	10	1250	75	44.1	8	116	68	3/4"	205	451	80 x 65 x 98
V60NH92FNM760	-	PLUS 8-10	7.5	10	1000	60	35.3	10	145	68	3/4"	205	451	80 x 65 x 98
V60NI92FNM760	-	PLUS 8-13	7.5	10	750	45	26.5	13	188	68	3/4"	205	451	80 x 65 x 98
V60NL92FNM760	-	PLUS 11-08	11	15	1650	99	58.2	8	116	69	3/4"	216	475	80 x 65 x 98
V60NM92FNM760	-	PLUS 11-10	11	15	1500	90	53	10	145	69	3/4"	216	475	80 x 65 x 98
V60NN92FNM760	-	PLUS 11-13	11	15	1100	66	38.8	13	188	69	3/4"	216	475	80 x 65 x 98
V60NP92FNM760	-	PLUS 15-08	15	20	2150	129	75.9	8	116	70	3/4"	220	484	80 x 65 x 98
V60NQ92FNM760	-	PLUS 15-10	15	20	1850	111	65.3	10	145	70	3/4"	220	484	80 x 65 x 98
V60NR92FNM760	-	PLUS 15-13	15	20	1500	90	53	13	188	70	3/4"	220	484	80 x 65 x 98
V60NB92FNM760	-	PLUS 16-08	15	20	2350	141	83	8	116	68	3/4"	234,5	516	80 x 65 x 98
V60NY92FNM760	-	PLUS 16-10	15	20	2050	123	72.4	10	145	68	3/4"	234,5	516	80 x 65 x 98
V60NW92FNM760	-	PLUS 16-13	15	20	1750	105	61.8	13	188	68	3/4"	234,5	516	80 x 65 x 98
WITH AIR RECEIVER														
V91NG92FNM701	270	PLUS 8-08-270	7.5	10	1250	75	44.1	8	116	68	3/4"	288	634	156 x 65 x 155
V91NH92FNM701	270	PLUS 8-10-270	7.5	10	1000	60	35.3	10	145	68	3/4"	288	634	156 x 65 x 155
V91NL92FNM701	270	PLUS 11-08-270	11	15	1650	99	58.2	8	116	69	3/4"	302	664	156 x 65 x 155
V91NM92FNM701	270	PLUS 11-10-270	11	15	1500	90	53	10	145	69	3/4"	302	664	156 x 65 x 155
V83NG92FNM701	500	PLUS 8-08-500	7.5	10	1250	75	44.1	8	116	68	3/4"	334	735	200 x 65 x 164
V83NH92FNM701	500	PLUS 8-10-500	7.5	10	1000	60	35.3	10	145	68	3/4"	334	735	200 x 65 x 164
V83NL92FNM701	500	PLUS 11-08-500	11	15	1650	99	58.2	8	116	69	3/4"	353	777	200 x 65 x 164
V83NM92FNM701	500	PLUS 11-10-500	11	15	1500	90	53	10	145	69	3/4"	353	777	200 x 65 x 164
V83NP92FNM701	500	PLUS 15-08-500	15	20	2150	129	75.9	8	116	70	3/4"	383	843	200 x 65 x 164
V83NQ92FNM701	500	PLUS 15-10-500	15	20	1850	111	65.3	10	145	70	3/4"	383	843	200 x 65 x 164
V83NB92FNM701	500	PLUS 16-08-500	15	20	2350	141	83	8	116	68	3/4"	410	902	200 x 65 x 164
V83NY92FNM701	500	PLUS 16-10-500	15	20	2050	123	72.4	10	145	68	3/4"	362	796	200 x 65 x 164
WITH AIR RECEIVER AND DRYER														
V91NG92FNM801	270	PLUS 8-08-270 ES	7.5	10	1250	75	44.1	8	116	68	3/4"	315	693	156 x 65 x 155
V91NH92FNM801	270	PLUS 8-10-270 ES	7.5	10	1000	60	35.3	10	145	68	3/4"	315	693	156 x 65 x 155
V91NL92FNM801	270	PLUS 11-08-270 ES	11	15	1650	99	58.2	8	116	69	3/4"	329	724	156 x 65 x 155
V91NM92FNM801	270	PLUS 11-10-270 ES	11	15	1500	90	53	10	145	69	3/4"	329	724	156 x 65 x 155
V83NG92FNM801	500	PLUS 8-08-500 ES	7.5	10	1250	75	44.1	8	116	68	3/4"	361	794	200 x 65 x 164
V83NH92FNM801	500	PLUS 8-10-500 ES	7.5	10	1000	60	35.3	10	145	68	3/4"	361	794	200 x 65 x 164
V83NL92FNM801	500	PLUS 11-08-500 ES	11	15	1650	99	58.2	8	116	69	3/4"	380	836	200 x 65 x 164
V83NM92FNM801	500	PLUS 11-10-500 ES	11	15	1500	90	53	10	145	69	3/4"	380	836	200 x 65 x 164
V83NP92FNM801	500	PLUS 15-08-500 ES	15	20	2150	129	75.9	8	116	70	3/4"	412	906	200 x 65 x 164
V83NQ92FNM801	500	PLUS 15-10-500 ES	15	20	1850	111	65.3	10	145	70	3/4"	412	906	200 x 65 x 164
V83NB92FNM801	500	PLUS 16-08-500 ES	15	20	2350	141	83	8	116	68	3/4"	439	966	200 x 65 x 164
V83NY92FNM801	500	PLUS 16-10-500 ES	15	20	2050	123	72.4	10	145	68	3/4"	436	959	200 x 65 x 164

ALL MODELS WITH AIR RECEIVER ARE ALSO AVAILABLE ON REQUEST WITH A WORKING PRESSURE OF 13 BAR, PROVIDING THE SAME PERFORMANCE OF MODELS ON GROUND.
Free air delivery as per ISO 1217 Annex C, at 7.5 - 9.5 - 12.5 bar at the compressor outlet. ± 3 dB (A) as PNEUROP/CAGI PN-NTC 2.3.









Code	Product			 AIR **			 MAX						
		kW	HP	l/min.	m ³ /h	c.f.m.	bar	psi	dB(A)	BSP	kg	Lbs	L x W x H (cm)
FLOOR MOUNTED													
V60QA92FNM760	PLUS 18.5-08	18.5	25	2800	168	99	8	116	66	3/4"	350	774	135 x 80 x 113
V60QB92FNM760	PLUS 18.5-10	18.5	25	2500	150	88	10	145	66	3/4"	350	774	135 x 80 x 113
V60QC92FNM760	PLUS 18.5-13	18.5	25	2150	129	76	13	188	66	3/4"	350	774	135 x 80 x 113
V60QD92FNM760	PLUS 22-08	22	30	3350	201	118	8	116	68	3/4"	380	840	135 x 80 x 113
V60QE92FNM760	PLUS 22-10	22	30	3000	180	106	10	145	68	3/4"	380	840	135 x 80 x 113
V60QF92FNM760	PLUS 22-13	22	30	2400	144	85	13	188	68	3/4"	380	840	135 x 80 x 113
WITH DRYER													
V60QA92FNM860	PLUS 18.5-08 ES	18.5	25	2800	168	99	8	116	66	3/4"	400	883	169 x 80 x 113
V60QB92FNM860	PLUS 18.5-10 ES	18.5	25	2500	150	88	10	145	66	3/4"	400	883	169 x 80 x 113
V60QC92FNM860	PLUS 18.5-13 ES	18.5	25	2150	129	76	13	188	66	3/4"	400	883	169 x 80 x 113
V60QD92FNM860	PLUS 22-08 ES	22	30	3350	201	118	8	116	68	3/4"	430	949	169 x 80 x 113
V60QE92FNM860	PLUS 22-10 ES	22	30	3000	180	106	10	145	68	3/4"	430	949	169 x 80 x 113
V60QF92FNM860	PLUS 22-13 ES	22	30	2400	144	85	13	188	68	3/4"	430	949	169 x 80 x 113
VARIABLE SPEED													
V60QD97FNM760	PLUS 22-08 VS	22	30	3350 / 1350	201 / 81	118 / 48	8	116	68	3/4"	390	861	135 x 80 x 113
V60QE97FNM760	PLUS 22-10 VS	22	30	3050 / 1220	183 / 73.2	108 / 43	10	145	68	3/4"	390	861	135 x 80 x 113
VARIABLE SPEED WITH DRYER													
V60QD97FNM860	PLUS 22-08 ES VS	22	30	3350 / 1350	201 / 81	118 / 48	8	116	68	3/4"	440	971	169 x 80 x 113
V60QE97FNM860	PLUS 22-10 ES VS	22	30	3050 / 1220	183 / 73.2	108 / 43	10	145	68	3/4"	440	971	169 x 80 x 113

Free air delivery as per ISO 1217 Annex C, at 7.5 - 9.5 - 12.5 bar at the compressor outlet. ± 3 dB (A) as PNEUROP/CAGI PN-NTC 2.3.

** Variable Speed models: max./min. values.



Code	Product			 AIR **			 MAX.						
		kW	HP	l/min.	m ³ /h	c.f.m.	bar	psi			kg	Lbs	
FLOOR MOUNTED													
V60BU92FNM760	PLUS 31-08	30	40	4700	282	165.9	8	116	70	1 -1/4"	630	1392	153 x 83 x 144
V60BV92FNM760	PLUS 31-10	30	40	4200	252	148.3	10	145	70	1 -1/4"	630	1392	153 x 83 x 144
V60BW92FNM760	PLUS 31-13	30	40	3400	204	120	13	188	70	1 -1/4"	630	1392	153 x 83 x 144
V60BK92FNM760	PLUS 38-08	37	50	6000	360	212	8	116	68	1 -1/4"	700	1547	153 x 83 x 144
V60BJ92FNM760	PLUS 38-10	37	50	5300	318	187	10	145	68	1 -1/4"	700	1547	153 x 83 x 144
V60BI92FNM760	PLUS 38-13	37	50	4000	240	141	13	188	68	1 -1/4"	700	1547	153 x 83 x 144
V60BM92FNM860	PLUS 45-08	45	60	7200	432	254	7.5	109	72	1 -1/2"	910	2002	160 x 97 x 186
V60BN92FNM860	PLUS 45-10	45	60	6500	390	229	10	145	72	1 -1/2"	910	2002	160 x 97 x 186
V60BQ92FNM860	PLUS 45-13	45	60	5100	306	180	13	188	72	1 -1/2"	910	2002	160 x 97 x 186
V60BR92FNM760	PLUS 55-08	55	75	8600	516	304	7.5	109	74	1 -1/2"	952	2094	160 x 97 x 186
V60BS92FNM760	PLUS 55-10	55	75	7800	468	275	10	145	74	1 -1/2"	952	2094	160 x 97 x 186
V60BT92FNM760	PLUS 55-13	55	75	6400	384	226	13	188	74	1 -1/2"	952	2094	160 x 97 x 186
V60BA92FNM760	PLUS 56-08	55	75	9300	558	328	7.5	109	70	2"	1650	3630	180 x 110 x 215
V60BB92FNM760	PLUS 56-10	55	75	8300	498	293	10	145	70	2"	1650	3630	180 x 110 x 215
V60BC92FNM760	PLUS 56-13	55	75	7000	420	247	13	188	70	2"	1650	3630	180 x 110 x 215
V60BD92FNM760	PLUS 75-08	75	100	12200	732	431	7.5	109	72	2"	1720	3784	180 x 110 x 215
V60BE92FNM760	PLUS 75-10	75	100	10500	630	371	10	145	72	2"	1720	3784	180 x 110 x 215
V60BF92FNM760	PLUS 75-13	75	100	8300	498	293	13	188	72	2"	1720	3784	180 x 110 x 215
WITH DRYER													
V60BU92FNM860	PLUS 31-08 ES	30	40	4700	282	165.9	8	116	70	1 -1/4"	710	1567	153 x 83 x 144
V60BV92FNM860	PLUS 31-10 ES	30	40	4200	252	148.3	10	145	70	1 -1/4"	710	1567	153 x 83 x 144
V60BW92FNM860	PLUS 31-13 ES	30	40	3400	204	120	13	188	70	1 -1/4"	710	1567	153 x 83 x 144
V60BK92FNM860	PLUS 38-08 ES	37	50	6000	360	212	8	116	68	1 -1/4"	780	1721	186 x 83 x 144
V60BJ92FNM860	PLUS 38-10 ES	37	50	5300	318	187	10	145	68	1 -1/4"	780	1721	186 x 83 x 144
V60BI92FNM860	PLUS 38-13 ES	37	50	4000	240	141	13	188	68	1 -1/4"	780	1721	186 x 83 x 144
VARIABLE SPEED													
V60BK97FNM760	PLUS 38-08 VS	37	50	5900 / 2350	354 / 141	208 / 83	8	116	72	1 -1/4"	725	1600	153 x 83 x 144
V60BJ97FNM760	PLUS 38-10 VS	37	50	5200 / 2050	312 / 123	184 / 72	10	145	72	1 -1/4"	725	1600	153 x 83 x 144
V60BA97FNM760	PLUS 56-08 VS	55	75	9300 / 3700	558 / 222	328 / 131	7.5	109	70	2"	1686	3721	180 x 110 x 215
V60BB97FNM760	PLUS 56-10 VS	55	75	8300 / 3300	498 / 198	293 / 116	10	145	70	2"	1686	3721	180 x 110 x 215
V60BD97FNM760	PLUS 75-08 VS	75	100	12200 / 4800	732 / 288	431 / 169	7.5	109	72	2"	1756	3875	180 x 110 x 215
V60BE97FNM760	PLUS 75-10 VS	75	100	10500 / 4200	630 / 252	371 / 148	10	145	72	2"	1756	3875	180 x 110 x 215
VARIABLE SPEED WITH DRYER													
V60BK97FNM860	PLUS 38-08 ES VS	37	50	5900 / 2350	354 / 141	208 / 83	8	116	72	1 -1/4"	805	1777	186 x 83 x 144
V60BJ97FNM860	PLUS 38-10 ES VS	37	50	5200 / 2050	312 / 123	184 / 72	10	145	72	1 -1/4"	805	1777	186 x 83 x 144

Free air delivery as per ISO 1217 Annex C, at 7.5 - 9.5 - 12.5 bar at the compressor outlet. ± 3 dB (A) as PNEUROP/CAGI PN-NTC 2.3.

** Variable Speed models: max./min. values.

A wide range of solutions for industrial applications



K-Max 5,5-37

Oil injection rotary screw compressors, with direct transmission without gears, at fixed or variable speed, and power values from 5.5 to 37 kW.



K-Max 45-90

Oil injection rotary screw compressors, with direct transmission without gears, from 45 to 90 kW.



Tera SD

Oil injection rotary screw compressors, with direct transmission without gears, at fixed or variable speed, and power values from 75 to 250 kW.



OS Scroll

Oil-free compressors with scroll spiral rotary system, at fixed or variable speed, and power values from 2.2 to 30 kW.



Trattamento Aria

Driers, filters, accessories and a vast range of products for compressed air treatment.



FNA S.p.A.

Production plant, registered office and Headquarter: Via Einaudi, 6 - 10070 Robassomero (TO) Italy

Tel. +39 011 9233000 - Fax +39 011 9241138

Production plant: Via Toscana, 21 - 40069 Zola Predosa (BO) Italy

Tel. 051 6168111 - Fax 051 752408

www.finicompressors.com - info@fnacompressors.com



CE IE3

MADE IN ITALY



INDUSTRIAL range



K-MAX

Direct drive oil-injected screw compressors



Fixed and variable speed
5.5-90 kW

Company Profile

Fini boasts more than 60 years of experience and is one of the most important global organisations in the professional and industrial compressed air sector. Synonymous with quality and professionalism, the Fini brand not only provides one of the most comprehensive ranges in the field of rotary air compressors, but above all Fini is now established as a global reference point in terms of quality and technology recognised throughout the industrial compressed air sector.



All Fini industrial compressors are **MADE IN ITALY**, designed for heavy duty use, and distinguished for their unique and advanced technologies that provides energy saving solutions that work!

► Our compressors offer the ideal solution to the needs of larger-scale industry as well as smaller and mid-sized companies, where compressed air is a most important source of energy.

Fini Screw Compressors are designed for continuous duty in the most arduous operating conditions, with a special attention to reducing energy consumption, lowering operating and maintenance costs along with offering simple installation and ease of use.

► The entire production process, from project design and research through to the packaging of the final product is carried out at our facilities in Italy.

Our highly skilled work force are dedicated to supporting the manufacturing and assembling activities.

The continuous control and monitoring of each manufacturing process grants the utmost precision at every step, in order to achieve the highest quality and supreme product reliability.

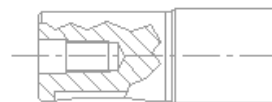

Innovation, Quality and Know-how

Our engineering philosophy is based on the selection and highly controlled assembly of the most reliable and efficient technical solutions. The constant pursuit of excellence in quality, along with an innovative spirit and particular attention to the customers demands, are the values that have always characterised Fini and its products.



► Ongoing investments in technical and product innovation have led Fini to boost its industrial product range with the **K-MAX: rotary screw compressors with direct or gears transmission system, with power values from 5.5 up to 90 kW.**

► Testing conducted on automated lines, state of the art automated systems and IT equipment intended for design and control are the main investments that the company has made in order to manufacture products that fulfil the quality standards of the market. Since 1996, the Company has certified its quality system in accordance with UNI EN ISO 9001:2015 standards.

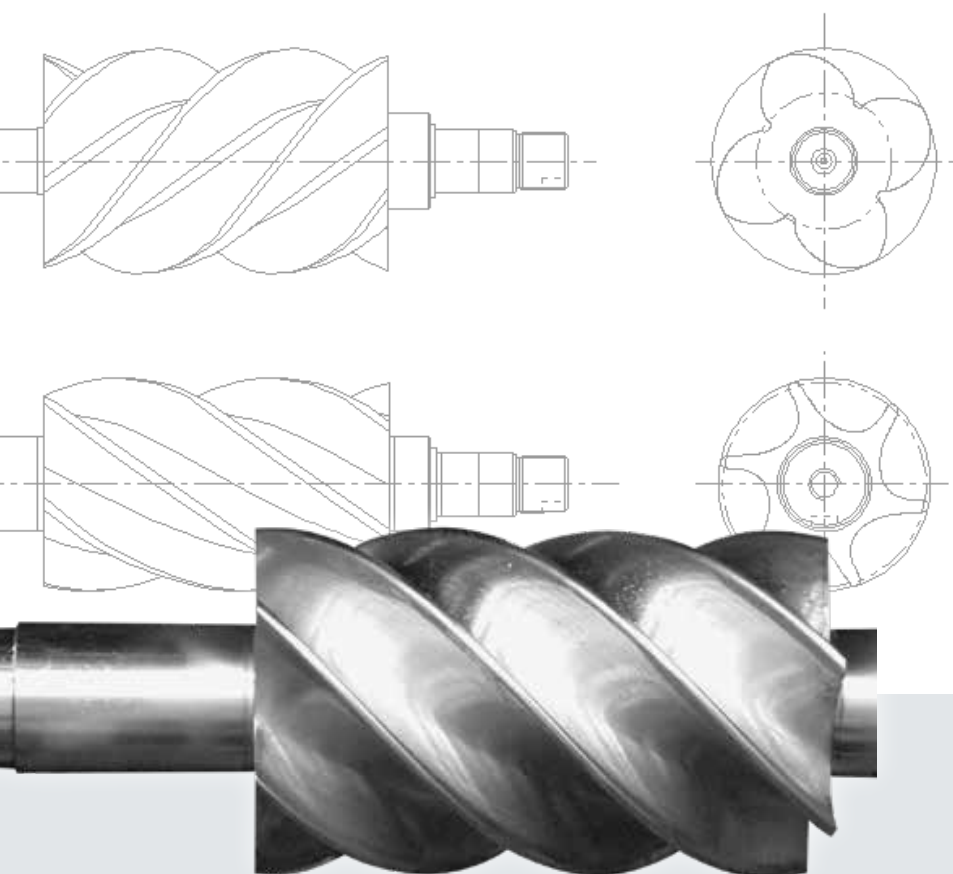

Our TARGET: maximum efficiency, lower energy consumption and low noise impact.

The K-MAX screw compressors from 5.5 to 90 kW have been designed to minimize energy costs without sacrificing performance. The original design has been developed to obtain the best cooling performance with the least acoustic impact. Available in fixed or variable speed version, with pressures of 7.5, 8, 10 or 13 bar.



The K-MAX range transmission system aims to maximize efficiency and reliability.

The direct or gear drive transmission minimises maintenance and increases the reliability and longevity of the machine. The combination of proven technologies, along with components designed and manufactured by Fini, guarantees high efficiency and constant maintenance of performance. In up to 15 kW compressors, power transmission without loss can bring a 4% advantage compared to a normal belt driven compressor, thanks to its special motor with a tubular crankcase and no frontal bearing.



▶ Transmission system with **tubular crankcase**, provided on the models: 5.5 - 7.5 - 11 - 15.



▶ Transmission system with **gears**, provided on the models: 22 - 31 - 45 - 55 - 75 - 75E.

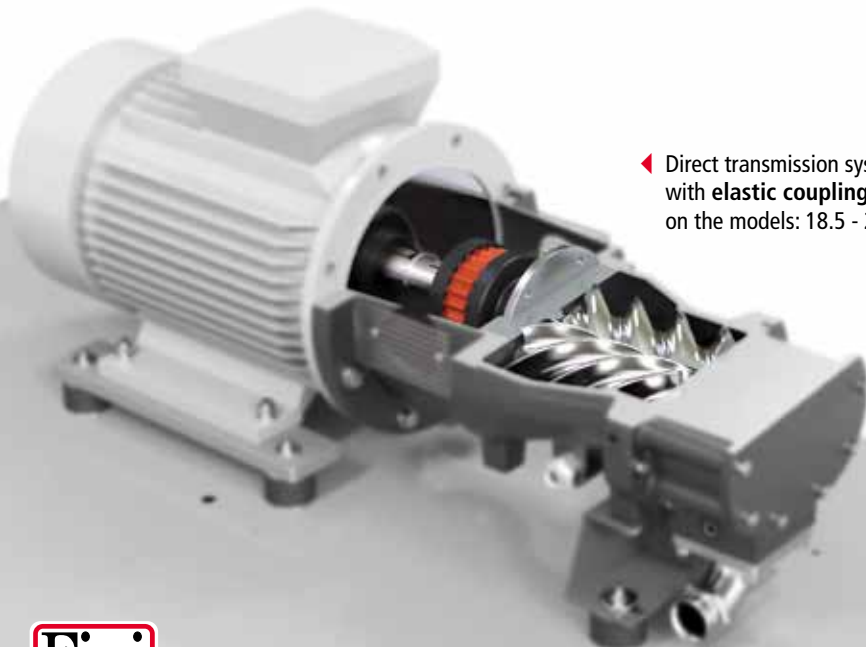

◀ Direct transmission system with **elastic coupling**, provided on the models: 18.5 - 22 - 31 - 38 - 45 - 55.

▼ Transmission system with **gears**, provided on the models: 76 - 90.



Why you should choose a Fini SCREW compressor?

- ▶ To have a 100% Italian product.
- ▶ To cut operating costs.
- ▶ To have the most modern, compact, efficient, reliable and quiet screw compressor.
- ▶ To provide a continuous source of compressed air.
- ▶ To monitor the remote compressor activity.
- ▶ To save energy and reduce CO₂ emissions.



High energy saving

The IE3 high efficiency motors, combined with high performance air-ends, allow you to cut energy costs. Moreover, IE3 motors reduce CO₂ emissions: an important contribution to protecting the environment.

Plug&Play

Our K-MAX compressors are thoroughly tested in our factories to ensure they are ready for immediate use following delivery, thereby saving time and cutting installation costs.



Low noise levels

K-MAX compressors are very quiet: efficient soundproofing materials, lower speed and radial cooling fans make them suitable for installation even near workstations.

Simplified maintenance

The use of selected components, supplied by leading manufacturers worldwide, guarantees a long operational life and long maintenance intervals. The constructive layout is designed to facilitate access to internal components and therefore all maintenance operations.

Remote monitoring

Thanks to the SMS Device, complete remote control of the compressor is possible from any device (Smartphone, Tablet, PC, etc.). The SMS Device, in addition, automatically sends e-mails in case of alarms and according to pre-established thresholds.

The air-ends, inverters and controllers are covered by a **2-YEAR WARRANTY** that can be extended up to 5 years by joining the Trust program (info on pages 22-23).

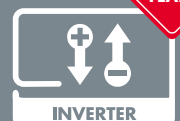

ETIV Advanced electronic controller

The advanced ETIV controller installed on the K-MAX range has been specially designed to ensure optimal monitoring and regulation of the operation of the compressor, allowing flexibility and complete programming, to ensure maximum efficiency and safety.



Controller with multi-function backlight LCD graphic display, the menu is drop down type. The main screen display indicates:

- ▶ operating pressure values;
- ▶ oil temperature values;
- ▶ compressor status (stand-by, idle, loaded);
- ▶ fan status (on/off);
- ▶ date and time;
- ▶ remaining hours for maintenance;
- ▶ drive speed percentage (for machines with an inverter)
- ▶ duty cycle compressor (total and load hours)

▶ Weekly programming

With the ETIV controller, it is possible to set up to 9 independent operating programs.

For each program it is possible to set the switching on and off times, the days of the week in which it must work and the relative pressure range.

In case of a system with several compressors, both at fixed and variable speed, it is possible to set various programs to create a "virtual network" (without the need to physically connect them together).

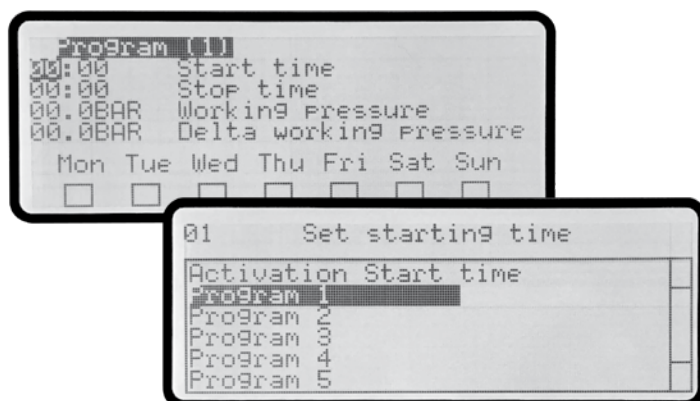

EasyX4 Optimised control in the compressor room

Many compressed air stations include several compressors: **EasyX4** is the easiest solution to manage complex compressor systems, with fixed speed, programmable on a weekly basis, capable of configuring up to 4 units, based on the amount of air actually required.

Three programming levels:

- ▶ **MANUAL:** compressors set on a given operating pressure range;
- ▶ **AUTOMATIC:** with pressure range exchange after a programmable time period;
- ▶ **GROUP PROGRAMMING:** the compressors can be switched within groups.

#405531604 EASY X4 CONTROL UNIT



SMS Device Service Management System

SMS is the innovative device for remote control and predictive maintenance of screw compressors fitted with an ETIV controller. If the device is configured on internet networks via Wi-Fi or Ethernet, e-mails can be automatically sent in case of faults and/or automatic periodic e-mails (every hour, every day, every week) so as to monitor correct compressor operation and the remaining hours for the main scheduled maintenance.

Preventive and targeted maintenance:

- ▶ automatic sending of e-mails in case of alarms,
- ▶ possibility of sending e-mails which notify the compressor status and settings at pre-set intervals (hourly, daily or weekly).

Remote control of the compressor:

- ▶ no additional software is required,
- ▶ on/off control,
- ▶ access to the various menu levels (user, service),
- ▶ compressor online status check.



9062744

ANTENNA+SMS DEVICE KIT

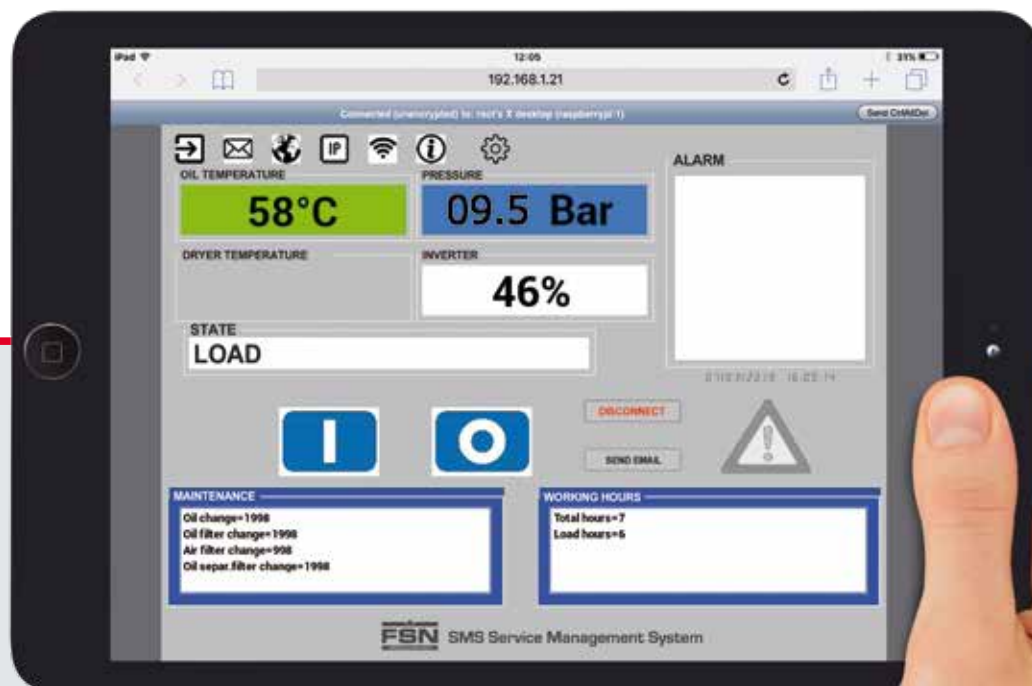

Variable speed to reduce energy consumption

Nowadays, reducing energy consumption and protecting our precious resources represent one of the greatest environmental challenges worldwide. The **K-MAX** series is also available in the Variable Speed version (VS models from 7.5 to 90 kW), offering high performance combined with energy-saving solutions.

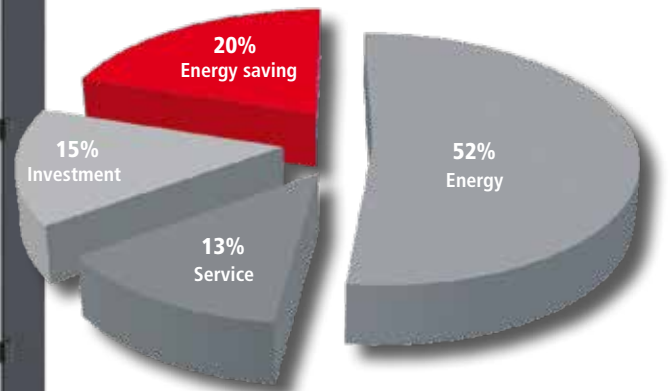

MANAGEMENT COSTS

The graph shows the significant energy saving using variable speed compressors in a typical installation.

The inverter application of a leading world manufacturer, able to dynamically adjust the voltage/frequency/current values of the motor, allows the elimination of unnecessary power losses by constantly adjusting the generation of compressed air to match the real air demand, offering many proven advantages for the user in terms of reducing energy consumption:

- ▶ Continuous regulation of the motor speed and compressed air generation to precisely match the air demand.
- ▶ The air output is constantly adjusted between 40% and 100% of the compressor full capacity.
- ▶ Constant and accurate air pressure.
- ▶ Energy consumption is proportional to the delivered compressed air.



EATool - EASoftware Detection and analysis of energy consumption

The energy efficiency of a production plant using compressed air allows for countless advantages for the company's entire production process, in terms of consumption and costs.

Based on decades of experience in the industrial sector, Fini provides a professional auditing service to companies, through skilled technicians and advanced measurement and analysis equipment (EATool and EASoftware). Such equipment allows us to offer one or more rotary screw compressors, in alternative to the existing ones, to achieve considerable annual economic and energy savings.



EATool

- ▶ Designed to measure pneumatic systems where up to 4 compressors work.
- ▶ Measurements are downloaded to a USB drive (included).
- ▶ Supplied: up to 4 x 400 A ampere clamps (optional up to 1000A) and a pressure probe.
- ▶ Possible equipment sale or rental.

EASoftware

- ▶ Acquires the actual consumption of a compressed air system.
- ▶ Processes a complete Energy Audit of the system.
- ▶ Suggests one or more compressors as an alternative to the existing ones, to achieve the highest energy savings.

9062747

EATOOL EA400

K-MAX 5.5-37 kW Designed for a long service life.



■ Innovative cooling system

The equipment has one of the most innovative cooling systems in the sector: a thermostatic-control centrifugal fan that ensures the temperature inside the compressor remains within a specific tolerance and at a constant level, avoiding temperature peaks that may prevent the machine from operating correctly. The action of the fan, combined with the efficiency of the oversize oil radiator, ensures that the compressor also operates under critical weather conditions.

The "silent" fans, the specially designed labyrinth ventilation and the use of top quality soundproofing materials ensure one of the lowest acoustic levels of the range.



K-MAX 11-15
front and rear view



■ Easy to transport

With the easily removable panel located at the base of the compressor, the machine can be effortlessly transported with a pallet truck or a forklift truck, whilst at the same time ensuring considerably lower noise levels. The versions on a tank are also equipped with lifting bars on the base, both at the front and the back.



■ Simplified maintenance

The oil filter and "spin-on" type of oil separator filter are easy to replace, offer a long service life and low maintenance costs.

Noise and temperature under control.



■ High performance

The screw air-ends, exclusively designed by Fini, are entirely manufactured and tested in our Italian factory; the special design of the rotor profile ensures high performance.



■ Cleaning and protection

The pre-filter panel separates incoming dust and keeps the inside of the machine clean, thereby increasing the life cycle of the internal components.



K-MAX 38
front and rear view



■ High-efficiency IE3 motors

In conjunction with Fini high performance screw units, the "Premium Efficiency" IE3 motors by a top global manufacturer ensure lower energy costs. Moreover, IE3 motors help reduce CO₂ emissions.



■ Intake valve

The intake valve is entirely designed and manufactured at our facilities. This most important device, adjusts the compressor's operation to guarantee minimum pressure during idle running and maximum savings upon start-up.

K-MAX 45-90 kW Designed for a long service life.



■ Thermostatic valve (only 75-76 and 90 versions)

Controls the coolant flow avoiding sudden temperature changes and reduces the risk of condensation being formed within the lubrication circuit.

■ Cleaning and protection ■

The pre-filter panel separates incoming dust and keeps the inside of the machine clean, thereby increasing the life cycle of the internal components.



■ Heat exchangers

Generously dimensioned coolers combining high efficiency heat transfer and low pressure losses.

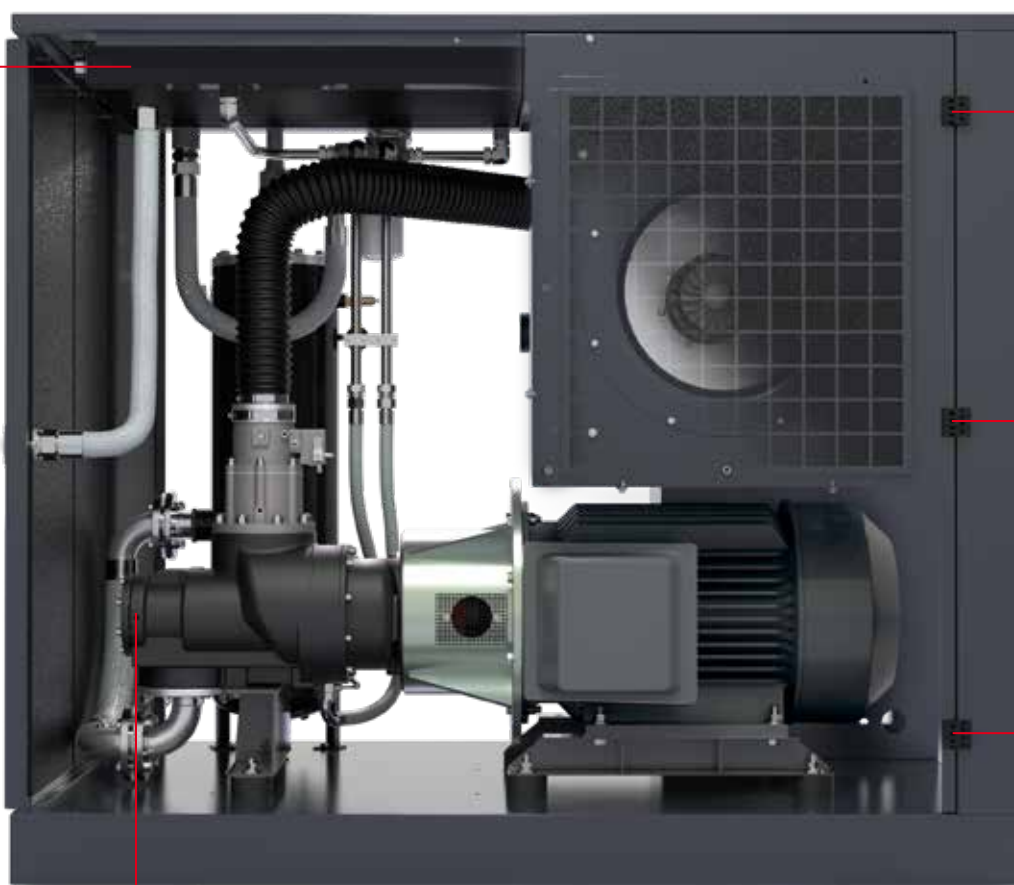

■ The machine can be fully opened on all 4 sides. The front and rear panels have hinges ensuring 180° opening.

◀ K-MAX 90 rear view



■ Simplified maintenance

The screw-motor unit is completely removable from the machine. The oil filter and air filter are ideally positioned for easy access, simplifying maintenance operations.

■ High efficiency air-ends

The special design of the rotor profile ensures high performance.



■ Energy saving

The intake regulator adjusts the compressor's operation to guarantee minimum pressure during idle running and maximum savings upon start-up.

Noise and temperature under control.



■ Innovative cooling system

The thermostatic-controlled centrifugal fan ensures the temperature inside the compressor remains within a specific tolerance and at a constant level, avoiding temperature peaks that may prevent the machine from operating correctly.

The action of the fan, combined with the efficiency of the oversized oil radiator, ensures that the compressor also operates under critical weather conditions.

The use of "silent" fans and top quality soundproofing materials ensure one of the lowest acoustic levels of its range.



◀ K-MAX 90
front view



■ Easy to transport

The palletized base allows a good portability of the machine with a pallet truck or a forklift truck.



■ High-efficiency IE3 motors

The "Premium Efficiency" IE3 motors by a top global manufacturer, combined with high-efficiency air-ends, ensure lower energy costs. Moreover, IE3 motors help to reduce CO₂ emissions.

K-MAX 5.5 - 15 kW: modular design.

The Fini K-MAX series from 5.5 to 15 kW is available in a variety of configurations to suit the exact requirements of the customer: starting with the standard floor mounted version, the range can also be selected with a 270 or 500 litre air receiver, with or without refrigerated dryer, also available with inverter (variable speed control) drive. The whole machine forms an extremely compact and aesthetic design.

- ▶ Direct drive technology for maximum reliability.
- ▶ High performances provides excellent efficiency.
- ▶ Intelligent microprocessor control system.
- ▶ Very compact design.
- ▶ No drive belts for less maintenance.
- ▶ "ES" versions are equipped with refrigerating air dryer, supplied ready to operate with a minimum of installation.



K-Max 5.5 - 7.5

5.5 - 7.5 kW

Available versions:

- floor mounted compressor
- compressor + air dryer (7.5 kW version only)
- compressor + air receiver
- compressor + air receiver + air dryer

- fixed speed
- variable speed (7.5 kW version only)

Air-end:

FSC 26

Controller:

ETIV

K-Max 11 - 15

11 - 15 kW

Available versions:

- floor mounted compressor
- compressor + air dryer
- compressor + air receiver
- compressor + air receiver + air dryer

- fixed and variable speed

Air-end:

FSC 50

Controller:

ETIV

K-MAX 18.5 - 37 kW: a quality choice.

Dryer module

Some K-MAX (up to 37 kW) are also available in the "ES" version with a refrigerated dryer: the dryer guarantees the production of dry and good quality air, which is essential to preserving the systems and the quality of the final product, and allows excellent performance to be achieved also in adverse environmental conditions and high inlet temperatures.



K-Max 18.5 - 22

18.5 - 22 kW

Available versions:

- floor mounted compressor
- compressor + air dryer (22 kW version only)
- fixed and variable speed

Air-end:

FS 100
FS 130

Controller:

ETIV

K-Max 31 - 38

30 - 37 kW

Available versions:

- floor mounted compressor
- compressor + air dryer (37 kW version only)
- fixed and variable speed

Air-end:

FS 190
FS 260

Controller:

ETIV

K-MAX 45 - 90 kW compact design meets high performance.



K-Max 45 - 55 - 75E

45-55-75 kW

Available versions:

- floor mounted compressor
- fixed and variable speed

Air-end

FS 260

Controller:

ETIV

K-Max 75 - 76 - 90

75-90 kW

Available versions:

- floor mounted compressor
- fixed and variable speed

Air-end:

FS 260 ("75" versions)
FS 300 ("76" and "90" versions)

Controller:

ETIV

5.5 - 7.5 kW

Model	CODE	ℓ	Free air delivered (max. / min)		MAX		dB(A)	BSP	Weight		Dimensions		Weight		Dimensions	
			kW	HP	m³/min.	c.f.m.			bar	psi	kg	Lbs	L x W x H (cm)	kg	Lbs	L x W x H (cm)
FIXED SPEED																
K-MAX 5.5-10	V51PS92FNM760	-	5.5	7.5	0.705	25	10	145	62	1/2"	162	357	83 x 68 x 85	176	388	94 x 77 x 103
K-MAX 5.5-10-270	V91PS92FNM701	270	5.5	7.5	0.705	25	10	145	62	1/2"	239	527	120 x 68 x 154	267	589	132 x 85 x 172
K-MAX 5.5-10-270 ES	V91PS92FNM801	270	5.5	7.5	0.705	25	10	145	62	1/2"	277	611	120 x 68 x 154	305	672	132 x 85 x 172
K-MAX 7.5-10	V51PT92FNM760	-	7.5	10	1.05	37	10	145	62	1/2"	165	364	83 x 68 x 85	179	395	94 x 77 x 103
K-MAX 7.5-13	V51PY92FNM760	-	7.5	10	0.7	25	13	189	62	1/2"	165	364	83 x 68 x 85	179	395	94 x 77 x 103
K-MAX 7.5-10 ES	V51PT92FNM860	-	7.5	10	1.05	37	10	145	62	1/2"	203	448	112 x 71 x 85	223	492	129 x 77 x 103
K-MAX 7.5-10-270	V91PT92FNM701	270	7.5	10	1.05	37	10	145	62	1/2"	242	534	120 x 68 x 154	270	595	132 x 85 x 172
K-MAX 7.5-10-500	V83PT92FNM701	500	7.5	10	1.05	37	10	145	62	1/2"	292	644	200 x 68 x 152	332	732	206,5 x 80 x 168
K-MAX 7.5-10-270 ES	V91PT92FNM801	270	7.5	10	1.05	37	10	145	62	1/2"	280	617	120 x 68 x 154	308	679	132 x 85 x 172
K-MAX 7.5-10-500 ES	V83PT92FNM801	500	7.5	10	1.05	37	10	145	62	1/2"	330	728	200 x 68 x 152	370	816	206,5 x 80 x 168
VARIABLE SPEED																
K-MAX 7.5-08 VS	V51QT97FNM760	-	7.5	10	1.3 / 0.6	46 / 21	8	116	63	1/2"	172	379	83 x 68 x 85	186	410	94 x 77 x 103
K-MAX 7.5-10 VS	V51PT97FNM760	-	7.5	10	1.1 / 0.5	39 / 18	10	145	63	1/2"	172	379	83 x 68 x 85	186	410	94 x 77 x 103
K-MAX 7.5-08 ES VS	V51QT97FNM860	-	7.5	10	1.3 / 0.6	46 / 21	8	116	63	1/2"	210	463	112 x 71 x 85	230	507	129 x 77 x 103
K-MAX 7.5-10 ES VS	V51PT97FNM860	-	7.5	10	1.1 / 0.5	39 / 18	10	145	63	1/2"	210	463	112 x 71 x 85	230	507	129 x 77 x 103
K-MAX 7.5-08-270 VS	V91QT97FNM701	270	7.5	10	1.3 / 0.6	46 / 21	8	116	63	1/2"	250	551	120 x 68 x 154	278	613	132 x 85 x 172
K-MAX 7.5-10-270 VS	V91PT97FNM701	270	7.5	10	1.1 / 0.5	39 / 18	10	145	63	1/2"	250	551	120 x 68 x 154	278	613	132 x 85 x 172
K-MAX 7.5-08-270 ES VS	V91QT97FNM801	270	7.5	10	1.3 / 0.6	46 / 21	8	116	63	1/2"	290	639	120 x 68 x 154	318	701	132 x 85 x 172
K-MAX 7.5-10-270 ES VS	V91PT97FNM801	270	7.5	10	1.1 / 0.5	39 / 18	10	145	63	1/2"	290	639	120 x 68 x 154	318	701	132 x 85 x 172

11 - 15 kW

Model	CODE	ℓ	Free air delivered (max. / min)		MAX		dB(A)	BSP	Weight		Dimensions		Weight		Dimensions	
			kW	HP	m³/min.	c.f.m.			bar	psi	kg	Lbs	L x W x H (cm)	kg	Lbs	L x W x H (cm)
FIXED SPEED																
K-MAX 11-08	V60PU92FNM760	-	11	15	1.7	60	8	116	67	3/4"	238	525	103 x 73 x 100	258	569	120 x 81 x 118
K-MAX 11-10	V60PJ92FNM760	-	11	15	1.55	55	10	145	67	3/4"	238	525	103 x 73 x 100	258	569	120 x 81 x 118
K-MAX 11-13	V60PW92FNM760	-	11	15	1.2	42	13	189	67	3/4"	238	525	103 x 73 x 100	258	569	120 x 81 x 118
K-MAX 11-08 ES	V60PU92FNM860	-	11	15	1.7	60	8	116	67	1"	283	624	140 x 76 x 100	303	668	150.5 x 81 x 118
K-MAX 11-10 ES	V60PJ92FNM860	-	11	15	1.55	55	10	145	67	1"	283	624	140 x 76 x 100	303	668	150.5 x 81 x 118
K-MAX 11-13 ES	V60PW92FNM860	-	11	15	1.2	42	13	189	67	1"	283	624	140 x 76 x 100	303	668	150.5 x 81 x 118
K-MAX 11-08-500	V83PU92FNM701	500	11	15	1.7	60	8	116	67	3/4"	365	805	200 x 73 x 166	405	893	206.5 x 80 x 185
K-MAX 11-10-500	V83PJ92FNM701	500	11	15	1.55	55	10	145	67	3/4"	365	805	200 x 73 x 166	405	893	206.5 x 80 x 185
K-MAX 11-13-500	V83PW92FNM701	500	11	15	1.2	42	13	189	67	3/4"	400	882	200 x 73 x 166	440	970	206.5 x 80 x 185
K-MAX 11-08-500 ES	V83PU92FNM801	500	11	15	1.7	60	8	116	67	3/4"	410	904	200 x 73 x 166	450	992	206.5 x 80 x 185
K-MAX 11-10-500 ES	V83PJ92FNM801	500	11	15	1.55	55	10	145	67	3/4"	410	904	200 x 73 x 166	450	992	206.5 x 80 x 185
K-MAX 11-13-500 ES	V83PW92FNM801	500	11	15	1.2	42	13	189	67	3/4"	445	981	200 x 73 x 166	485	1069	206.5 x 80 x 185
K-MAX 15-10	V60PV92FNM760	-	15	20	2.1	74	10	145	67	3/4"	248	547	103 x 73 x 100	268	591	120 x 81 x 121
K-MAX 15-13	V60PX92FNM760	-	15	20	1.55	55	13	189	67	3/4"	248	547	103 x 73 x 100	268	591	120 x 81 x 121
K-MAX 15-10 ES	V60PV92FNM860	-	15	20	2.1	74	10	145	67	1"	293	646	140 x 76 x 100	313	690	150.5 x 81 x 118
K-MAX 15-13 ES	V60PX92FNM860	-	15	20	1.55	55	13	189	67	1"	293	646	140 x 76 x 100	313	690	150.5 x 81 x 118
K-MAX 15-10-500	V83PV92FNM701	500	15	20	2.1	74	10	145	67	3/4"	375	827	200 x 73 x 166	415	915	206.5 x 85 x 185
K-MAX 15-13-500	V83PX92FNM701	500	15	20	1.55	55	13	189	67	3/4"	406	895	200 x 73 x 166	446	983	206.5 x 85 x 185
K-MAX 15-10-500 ES	V83PV92FNM801	500	15	20	2.1	74	10	145	67	3/4"	420	926	200 x 73 x 166	460	1014	206.5 x 85 x 185
K-MAX 15-13-500 ES	V83PX92FNM801	500	15	20	1.55	55	13	189	67	3/4"	455	1003	200 x 73 x 166	495	1091	206.5 x 85 x 185
VARIABLE SPEED																
K-MAX 11-08 VS	V60PU97FNM760	-	11	15	1.7 / 0.68	60 / 24	8	116	67	3/4"	246	542	103 x 73 x 100	266	586	120 x 81 x 118
K-MAX 11-10 VS	V60PJ97FNM760	-	11	15	1.58 / 0.62	56 / 22	10	145	67	3/4"	246	542	103 x 73 x 100	266	586	120 x 81 x 118
K-MAX 11-08 ES VS	V60PU97FNM860	-	11	15	1.7 / 0.68	60 / 24	8	116	67	1"	290	639	140 x 76 x 100	310	683	150.5 x 81 x 118
K-MAX 11-10 ES VS	V60PJ97FNM860	-	11	15	1.58 / 0.62	56 / 22	10	145	67	1"	290	639	140 x 76 x 100	310	683	150.5 x 81 x 118
K-MAX 11-08-500 VS	V83PU97FNM701	500	11	15	1.7 / 0.68	60 / 24	8	116	67	3/4"	372	820	200 x 73 x 166	402	886	206.5 x 80 x 185
K-MAX 11-10-500 VS	V83PJ97FNM701	500	11	15	1.58 / 0.62	56 / 22	10	145	67	3/4"	372	820	200 x 73 x 166	402	886	206.5 x 80 x 185
K-MAX 11-08-500 ES VS	V83PU97FNM801	500	11	15	1.7 / 0.68	60 / 24	8	116	67	3/4"	420	926	200 x 73 x 166	460	1014	206.5 x 80 x 185
K-MAX 11-10-500 ES VS	V83PJ97FNM801	500	11	15	1.58 / 0.62	56 / 22	10	145	67	3/4"	420	926	200 x 73 x 166	460	1014	206.5 x 80 x 185
K-MAX 15-08 VS	V60PI97FNM760	-	15	20	2.5 / 0.95	88 / 34	8	116	67	3/4"	263	580	103 x 73 x 100	283	624	120 x 81 x 121
K-MAX 15-10 VS	V60PV97FNM760	-	15	20	2.1 / 0.84	74 / 30	10	145	67	3/4"	263	580	103 x 73 x 100	283	624	120 x 81 x 121
K-MAX 15-08 ES VS	V60PI97FNM860	-	15	20	2.5 / 0.95	88 / 34	8	116	67	1"	308	679	140 x 76 x 100	328	723	150.5 x 81 x 118
K-MAX 15-10 ES VS	V60PV97FNM860	-	15	20	2.1 / 0.84	74 / 30	10	145	67	1"	308	679	140 x 76 x 100	328	723	150.5 x 81 x 118
K-MAX 15-08-500 VS	V83PI97FNM701	500	15	20	2.5 / 0.95	88 / 34	8	116	67	3/4"	390	860	200 x 73 x 166	430	948	206.5 x 85 x 185
K-MAX 15-10-500 VS	V83PV97FNM701	500	15	20	2.1 / 0.84	74 / 30	10	145	67	3/4"	390	860	200 x 73 x 166	430	948	206.5 x 85 x 185
K-MAX 15-08-500 ES VS	V83PI97FNM801	500	15	20	2.5 / 0.95	88 / 34	8	116	67	3/4"	435	959	200 x 73 x 166	475	1047	206.5 x 85 x 185
K-MAX 15-10-500 ES VS	V83PV97FNM801	500	15	20	2.1 / 0.84	74 / 30	10	145	67	3/4"	435	959	200 x 73 x 166	475	1047	206.5 x 85 x 185

Free air delivery as per ISO 1217 Annex C, at 7.5 - 9.5 - 12.5 bar at the compressor outlet. ± 3 dB (A) as PNEUROP/CAGI PN-NTC 2.3.

ES = WITH AIR DRYER

VS = VARIABLE SPEED

18.5 - 22 kW

Model	CODE	ℓ	Compressor		Free air delivered (max. / min)		MAX		dB(A)	BSP	Weight		Dimensions		Weight		Dimensions	
			kW	HP	m³/min.	c.f.m.	bar	psi			kg	Lbs	L x W x H (cm)	kg	Lbs	L x W x H (cm)		
FIXED SPEED																		
K-MAX 18.5-10	V60DQ92FNM060	-	18.5	25	2.6	92	10	145	62	1-1/4"	526	1,160	133 x 85 x 137	607	1,338	153 x 104 x 166		
VARIABLE SPEED																		
K-MAX 18.5-08 VS	V60DP97FNM060	-	18.5	25	3.1 / 1.07	109 / 38	7.5	109	62	1-1/4"	541	1,193	133 x 85 x 137	622	1,371	153 x 104 x 166		
K-MAX 18.5-10 VS	V60DQ97FNM060	-	18.5	25	2.6 / 0.93	92 / 33	10	145	62	1-1/4"	541	1,193	133 x 85 x 137	622	1,371	153 x 104 x 166		

Model	CODE	ℓ	Compressor		Free air delivered (max. / min)		MAX		dB(A)	BSP	Weight		Dimensions		Weight		Dimensions	
			kW	HP	m³/min.	c.f.m.	bar	psi			kg	Lbs	L x W x H (cm)	kg	Lbs	L x W x H (cm)		
FIXED SPEED																		
K-MAX 22-08	V60DR92FNM060	-	22	30	3.6	127	7.5	109	58	1-1/4"	515	1,135	133 x 85 x 137	596	1,314	153 x 104 x 166		
K-MAX 22-08 ES	V60DR92FNM160	-	22	30	3.6	127	7.5	109	58	1-1/4"	572	1,261	171 x 85 x 137	662	1,459	205.5 x 114 x 166		
VARIABLE SPEED																		
K-MAX 22-08 VS	V60DR97FNM060	-	22	30	3.6 / 1.17	127 / 41	7.5	109	62	1-1/4"	530	1,168	133 x 85 x 137	611	1,347	153 x 104 x 166		
K-MAX 22-10 VS	V60DS97FNM060	-	22	30	3.01 / 1.17	106 / 41	10	145	60	1-1/4"	530	1,168	133 x 85 x 137	611	1,347	153 x 104 x 166		
K-MAX 22-13 VS	V60DT97FNM060	-	22	30	2.56 / 0.97	90 / 34	13	189	60	1-1/4"	530	1,168	133 x 85 x 137	611	1,347	153 x 104 x 166		
K-MAX 22-08 ES VS	V60DR97FNM160	-	22	30	3.6 / 1.17	127 / 41	7.5	109	62	1-1/4"	587	1,294	171 x 85 x 137	677	1,493	205.5 x 114 x 166		
K-MAX 22-10 ES VS	V60DS97FNM160	-	22	30	3.01 / 1.17	106 / 41	10	145	60	1-1/4"	587	1,294	171 x 85 x 137	677	1,493	205.5 x 114 x 166		
K-MAX 22-13 ES VS	V60DT97FNM160	-	22	30	2.56 / 0.97	90 / 34	13	189	60	1-1/4"	587	1,294	171 x 85 x 137	677	1,493	205.5 x 114 x 166		

30 - 37 kW

Model	CODE	ℓ	Compressor		Free air delivered (max. / min)		MAX		dB(A)	BSP	Weight		Dimensions		Weight		Dimensions	
			kW	HP	m³/min.	c.f.m.	bar	psi			kg	Lbs	L x W x H (cm)	kg	Lbs	L x W x H (cm)		
FIXED SPEED																		
K-MAX 31-08 *	V60DY92FNM060	-	30	40	4.85	171	7.5	109	68	1-1/2"	822	1,812	159 x 100 x 156	909	2,004	180 x 120 x 190		
K-MAX 31-10 *	V60DX92FNM060	-	30	40	4.3	152	10	145	68	1-1/2"	822	1,812	159 x 100 x 156	909	2,004	180 x 120 x 190		
VARIABLE SPEED																		
K-MAX 31-08 VS	V60DY97FNM060	-	30	40	4.85 / 1.99	171 / 70	7.5	109	66	1-1/2"	845	1,863	159 x 100 x 156	932	2,055	180 x 120 x 190		
K-MAX 31-10 VS	V60DX97FNM060	-	30	40	4.3 / 1.61	152 / 57	10	145	66	1-1/2"	845	1,863	159 x 100 x 156	932	2,055	180 x 120 x 190		

Model	CODE	ℓ	Compressor		Free air delivered (max. / min)		MAX		dB(A)	BSP	Weight		Dimensions		Weight		Dimensions	
			kW	HP	m³/min.	c.f.m.	bar	psi			kg	Lbs	L x W x H (cm)	kg	Lbs	L x W x H (cm)		
FIXED SPEED																		
K-MAX 38-08	V60DU92FNM060	-	37	50	6.6	233	7.5	109	70	1-1/2"	902	1,989	159 x 100 x 156	989	2,180	180 x 120 x 190		
K-MAX 38-08 ES	V60DU92FNM160	-	37	50	6.6	233	7.5	109	70	1-1/2"	982	2,165	196 x 100 x 156	1,079	2,379	213 x 120 x 190		
VARIABLE SPEED																		
K-MAX 38-08 VS	V60DU97FNM060	-	37	50	6.6 / 2.68	233 / 95	7.5	109	69	1-1/2"	925	2,039	159 x 100 x 156	1,012	2,231	180 x 120 x 190		
K-MAX 38-10 VS	V60DV97FNM060	-	37	50	5.4 / 1.72	191 / 61	10	145	66	1-1/2"	985	2,172	159 x 100 x 156	1,072	2,363	180 x 120 x 190		
K-MAX 38-13 VS	V60DW97FNM060	-	37	50	4.52 / 1.71	160 / 60	13	189	66	1-1/2"	985	2,172	159 x 100 x 156	1,072	2,363	180 x 120 x 190		
K-MAX 38-08 ES VS	V60DU97FNM160	-	37	50	6.6 / 2.68	233 / 95	7.5	109	69	1-1/2"	1,005	2,216	196 x 100 x 156	1,102	2,429	213 x 120 x 190		
K-MAX 38-10 ES VS	V60DV97FNM160	-	37	50	5.4 / 1.72	191 / 61	10	145	66	1-1/2"	1,065	2,348	196 x 100 x 156	1,162	2,562	213 x 120 x 190		
K-MAX 38-13 ES VS	V60DW97FNM160	-	37	50	4.52 / 1.71	160 / 60	13	189	66	1-1/2"	1,065	2,348	196 x 100 x 156	1,162	2,562	213 x 120 x 190		

* Drive with gears.

ES = WITH AIR DRYER

VS = VARIABLE SPEED

45 - 55 - 75 kW

Model	CODE	ℓ	Compressor		Free air delivered (max. / min)		Pressure		dB(A)	BSP	Weight		Dimensions		Dimensions	
			kW	HP	m³/min.	c.f.m.	bar	psi			kg	Lbs	L x W x H (cm)	kg	Lbs	L x W x H (cm)
FIXED SPEED																
K-MAX 45-08 *	V60FU92FNM060	-	45	60	8.2	290	7.5	109	72	2"	1,251	2,758	170 x 125 x 170	1,362	3,003	192 x 142 x 188
K-MAX 45-10	V60FV92FNM060	-	45	60	6.7	237	10	145	72	2"	1,194	2,632	170 x 125 x 170	1,305	2,877	192 x 142 x 188
VARIABLE SPEED																
K-MAX 45-08 VS	V60FU97FNM060	-	45	60	8.2 / 3	290 / 106	7.5	109	72	2"	1,222	2,694	170 x 125 x 170	1,326	2,923	192 x 142 x 188
K-MAX 45-10 VS	V60FV97FNM060	-	45	60	6.7 / 2.4	237 / 85	10	145	72	2"	1,222	2,694	170 x 125 x 170	1,326	2,923	192 x 142 x 188

Model	CODE	ℓ	Compressor		Free air delivered (max. / min)		Pressure		dB(A)	BSP	Weight		Dimensions		Dimensions	
			kW	HP	m³/min.	c.f.m.	bar	psi			kg	Lbs	L x W x H (cm)	kg	Lbs	L x W x H (cm)
FIXED SPEED																
K-MAX 55-08 *	V60FW92FNM060	-	55	75	10.1	357	7.5	109	72	2"	1,251	2,758	170 x 125 x 170	1,355	2,987	192 x 142 x 188
K-MAX 55-10 *	V60FX92FNM060	-	55	75	8.3	293	10	145	72	2"	1,251	2,758	170 x 125 x 170	1,355	2,987	192 x 142 x 188
K-MAX 55-13	V60FY92FNM060	-	55	75	6.5	230	13	189	72	2"	1,251	2,758	170 x 125 x 170	1,355	2,987	192 x 142 x 188
K-MAX 75E-08 *	V60QU92FNM060	-	75	100	12.6	445	7.5	109	72	2"	1,440	3,175	170 x 125 x 170	1,560	3,439	192 x 142 x 188
K-MAX 75E-10 *	V60QV92FNM060	-	75	100	10.5	371	10	145	72	2"	1,440	3,175	170 x 125 x 170	1,560	3,439	192 x 142 x 188
K-MAX 75E-13 *	V60QW92FNM060	-	75	100	8.7	307	13	189	72	2"	1,440	3,175	170 x 125 x 170	1,560	3,439	192 x 142 x 188
VARIABLE SPEED																
K-MAX 55-08 VS *	V60FW97FNM060	-	55	75	10.1 / 3.6	357 / 127	7.5	109	72	2"	1,279	2,820	170 x 125 x 170	1,383	3,049	192 x 142 x 188
K-MAX 55-10 VS	V60FX97FNM060	-	55	75	8.3 / 3	293 / 106	10	145	72	2"	1,279	2,820	170 x 125 x 170	1,383	3,049	192 x 142 x 188
K-MAX 55-13 VS	V60FY97FNM060	-	55	75	6.5 / 2.3	230 / 81	13	189	72	2"	1,279	2,820	170 x 125 x 170	1,383	3,049	192 x 142 x 188
K-MAX 75E-08 VS *	V60QU97FNM060	-	75	100	12.6 / 4.5	445 / 159	7.5	109	69	2"	1,486	3,276	170 x 125 x 170	1,600	3,527	192 x 142 x 188
K-MAX 75E-10 VS *	V60QV97FNM060	-	75	100	10.5 / 3.8	371 / 134	10	145	69	2"	1,486	3,276	170 x 125 x 170	1,600	3,527	192 x 142 x 188
K-MAX 75E-13 VS *	V60QW97FNM060	-	75	100	8.7 / 3.48	307 / 123	13	189	69	2"	1,486	3,276	170 x 125 x 170	1,600	3,527	192 x 142 x 188

75 - 90 kW

Mode	CODE	ℓ	Compressor		Free air delivered (max. / min)		Pressure		dB(A)	BSP	Weight		Dimensions		Dimensions	
			kW	HP	m³/min.	c.f.m.	bar	psi			kg	Lbs	L x W x H (cm)	kg	Lbs	L x W x H (cm)
FIXED SPEED																
K-MAX 75-08 *	V60FA92FNM160	-	75	100	12.6	445	7.5	109	69	2"	2,760	6,085	230 x 146 x 196	2,940	6,482	256 x 166 x 223
K-MAX 75-10 *	V60FB92FNM160	-	75	100	10.5	371	10	145	69	2"	2,760	6,085	230 x 146 x 196	2,940	6,482	256 x 166 x 223
K-MAX 75-13 *	V60FC92FNM160	-	75	100	8.7	307	13	189	69	2"	2,760	6,085	230 x 146 x 196	2,940	6,482	256 x 166 x 223
K-MAX 76-08	V60FA92FNM060	-	75	100	13.5	477	7.5	109	67	2"	2,890	6,371	230 x 146 x 196	3,070	6,768	256 x 166 x 223
K-MAX 76-10	V60FB92FNM060	-	75	100	11.7	413	10	145	67	2"	2,890	6,371	230 x 146 x 196	3,070	6,768	256 x 166 x 223
K-MAX 76-13	V60FC92FNM060	-	75	100	9.7	343	13	189	67	2"	2,890	6,371	230 x 146 x 196	3,070	6,768	256 x 166 x 223
VARIABLE SPEED																
K-MAX 75-08 VS *	V60FA97FNM160	-	75	100	12.6 / 4.5	445 / 159	7.5	109	69	2"	2,820	6,217	230 x 146 x 196	3,000	6,614	256 x 166 x 223
K-MAX 75-10 VS *	V60FB97FNM160	-	75	100	10.5 / 3.8	371 / 134	10	145	69	2"	2,820	6,217	230 x 146 x 196	3,000	6,614	256 x 166 x 223
K-MAX 75-13 VS *	V60FC97FNM160	-	75	100	8.7 / 3.48	307 / 123	13	189	69	2"	2,820	6,217	230 x 146 x 196	3,000	6,614	256 x 166 x 223
K-MAX 76-08 VS	V60FA97FNM060	-	75	100	13.5 / 4.9	477 / 173	7.5	109	67	2"	2,935	6,471	230 x 146 x 196	3,115	6,867	256 x 166 x 223
K-MAX 76-10 VS	V60FB97FNM060	-	75	100	11.7 / 4.2	413 / 148	10	145	66	2"	2,935	6,471	230 x 146 x 196	3,115	6,867	256 x 166 x 223
K-MAX 76-13 VS	V60FC97FNM060	-	75	100	9.7 / 3.5	343 / 124	13	189	67	2"	2,935	6,471	230 x 146 x 196	3,115	6,867	256 x 166 x 223

Model	CODE	ℓ	Compressor		Free air delivered (max. / min)		Pressure		dB(A)	BSP	Weight		Dimensions		Dimensions	
			kW	HP	m³/min.	c.f.m.	bar	psi			kg	Lbs	L x W x H (cm)	kg	Lbs	L x W x H (cm)
FIXED SPEED																
K-MAX 90-08	V60FH92FNM060	-	90	125	15.9	562	7.5	109	67	2"	2,927	6,453	230 x 146 x 196	3,107	6,850	256 x 166 x 223
K-MAX 90-10	V60FJ92FNM060	-	90	125	13.4	473	10	145	67	2"	2,927	6,453	230 x 146 x 196	3,107	6,850	256 x 166 x 223
K-MAX 90-13	V60FK92FNM060	-	90	125	10.4	367	13	189	67	2"	2,927	6,453	230 x 146 x 196	3,107	6,850	256 x 166 x 223
VARIABLE SPEED																
K-MAX 90-08 VS	V60FH97FNM060	-	90	125	15.9 / 5.7	562 / 201	7.5	109	68	2"	2,981	6,572	230 x 146 x 196	3,161	6,969	256 x 166 x 223
K-MAX 90-10 VS	V60FJ97FNM060	-	90	125	13.4 / 4.8	473 / 170	10	145	70	2"	2,981	6,572	230 x 146 x 196	3,161	6,969	256 x 166 x 223
K-MAX 90-13 VS	V60FK97FNM060	-	90	125	10.4 / 3.7	367 / 131	13	189	66	2"	2,981	6,572	230 x 146 x 196	3,161	6,969	256 x 166 x 223

Free air delivery as per ISO 1217 Annex C, at 7 - 9.5 - 12.5 bar at the compressor outlet. ± 3 dB (A) as PNEUROP/CAGI PN-NTC 2.3.

* Drive with gears.

VS = VARIABLE SPEED

Long Life Kit for screw compressors scheduled maintenance.

- ▶ **FSN original spare parts** have been rigorously selected, checked and tested by specialised technicians to ensure the utmost efficiency and endurance of the compressor. The parts are stocked in our "LOGIMAT" centralised and automated warehouse in Zola Predosa (BO) - Italy, where 12,000 part codes on 10,000 sqm are managed every day.
- ▶ Specialised staff are continuously in contact with our distribution centres worldwide, to deliver spare parts to our customers in the shortest possible time.
- ▶ To make it easier to replace components throughout the various maintenance intervals specified in the use and maintenance manuals, Fini developed its **LONG LIFE KITS**, specifically created for all screw compressor models. Using Long Life Kit ensures the maximum performances of the compressor. You can download the LLK catalogues from the website www.finicompressors.com and see the exploded drawings and spare parts, constantly updated for each compressor model.



LONG LIFE KIT

MANUTENZIONE PROGRAMMATA - SCHEDULED MAINTENANCE

FSN

K-MAX 18.5 - 30 kW

Intervallo (h)	Kit A	Kit B
ogni 2.000 h	Kit A	Kit B
ogni 4.000 h	Kit A	Kit B
ogni 8.000 h	Kit A	Kit B

K-MAX 18.5 - 30 kW

Componente	Quantità	Numero di parte
...



RotarEcofluid mineral based lubricants

- ▶ Formulated with high quality selected mineral base oils enhanced with advanced anti-oxidants, anti-wear (zinc free), rust preventers and antifoams, the **FSN RotarECOFLUID** oil offers an optimal control of oxidation and residue deposits as well as an excellent level of thermal stability and oxidation to ensure the longevity of equipment and long life performances.

#600000020	RotarECOFLUID 46 cSt - 1 x 3.8 L (3.3 kg) tank
#600000021	RotarECOFLUID 46 cSt - 1 x 20 L (17.36 kg) tank
#600000022	RotarECOFLUID 46 cSt - 1 x 200 L (174 kg) drum



RotEnergy synthetic based lubricants

- ▶ Our synthetic based lubricants - **FSN RotEnergy** - have been specifically designed for use on our screw compressors, supplied by the world leading manufacturers. They are available in cans, drums or multiple packages: **RotEnergyPlus**: ensures quick water separation and lower frictions and energy consumptions, extends maintenance intervals and ensures excellent lubrication of the bearings while offering an excellent protection. **RotEnergyFood**: a high quality lubricant for rotary compressors, suitable for use in the food industry, where specific quality standards are required.

We recommend changing synthetic or mineral oil according to the schedule provided in the compressor use and maintenance manual, or once a year. We suggest using our RotarECOFLUID and RotEnergy oil.

#600000018A	RotEnergyPlus 46 cSt - 1 x 3.8 L (3.25 kg) tank
#600000009A	RotEnergyPlus 46 cSt - 4 tanks x 3.8 L (3.25 kg) each
#600000007A	RotEnergyPlus 46 cSt - 1 x 19 L (16 kg) tank
#600000012A	RotEnergyPlus 46 cSt - 1 x 208 L (181 kg) drum

#600000014A	RotEnergyFood 46 cSt - 4 tanks x 3.9 L (3.25 kg) each
#600000016A	RotEnergyFood 46 cSt - 1 x 19 L (18.5 kg) tank
#600000017A	RotEnergyFood 46 cSt - 1 x 208 L (175 kg) drum

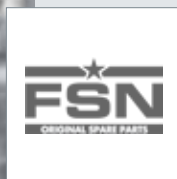

- ▶ All the exploded drawings and the spare parts lists for every compressor model are available at any time on the Fini and FSN website: www.finicompressors.com
- ▶ Our "Hot-Line" service is able to prepare and ship urgent orders on the same day.



- *Easy and fast online activation.*
- *You can choose to extend warranty to 3 or 5 years.*
- *Lower maintenance costs as a result of using original spare parts.*
- *Qualified assistance by authorised technicians.*



- WARRANTY EXTENSION
- ORDER ENTRY
- HOT LINE ORDER
- PROMO

The "Trust" warranty can be easily extended online through EasyConnect, the new Fini service portal specially created to simplify customers' lives by providing them with quick, clear responses about product availability, order management and goods shipping times.



Protect your investment, extend the Warranty up to **5** years!

When installing your new Fini screw compressor, join the "Trust" Warranty 3- to 5-year extension program to benefit from countless advantages by maximising the effectiveness, safety and duration over time of your investment. Thanks to scheduled maintenance programs exclusively performed by FINI Authorised Assistance Centres, you can rely on timely, highly professional service, as well as on the use of only original spare parts guaranteed by the FSN brand.



A wide range of solutions for industrial applications



TERA

Oil-injected rotary screw compressors, with direct transmission without gears, at fixed or variable speed and power values from 110 to 250 kW.



MICRO - PLUS

Oil-injected rotary screw compressors, with belt transmission, at fixed or variable speed and power values from 2.2 to 75 kW.



OS Scroll

Single and multi-scroll fixed speed oil-free compressors with power values from 2.2 to 30 kW.



AIR TREATMENT

Air driers, filters, accessories and a wide range of products for compressed air treatment.



PROFESSIONAL

Pumping units, base-plates and piston coaxial and belt-driven compressors, with power values from 0.75 to 20 HP.



FNA S.p.A.

Registered office and Headquarter: Via Einaudi, 6 - 10070 Robassomero (TO) - Italy

Production plant: Via Toscana, 21 - 40069 Zola Predosa (BO) - Italy

Tel.: +39 011 9233000 - Fax: +39 011 9241138

www.finicompressors.com - info@fnacompressors.com

